

Automotive Body Repair and Paint Work Level-II

Based on March 2022, Curriculum Version 1



**Module Title: - Interpreting Working Drawings and
Sketches**

Module code: EIS AUM1 M03 0822

Nominal duration: 40Hours

Prepared by: Ministry of Labour and Skill

**September , 2022
Addis Ababa, Ethiopia**

Table of Content

Acknowledgment.....	3
Acronym	4
Introduction to the Module.....	5
Unit one: Identifying technical drawing.....	6
1.1. Identify technical drawing	7
1.2. Identifying materials and dimensions	8
1.3. Free hand sketch	15
1.4. Checking and validating drawing	16
Self-check-1	18
Operation sheet-1.1	19
Operation sheet 1.2.....	21
LAP Test	22
Unit Two: Identify views, standard symbols and lines.....	23
2.1. Identifying Orthographic and isometric views	24
2.2. Identifying and explaining alphabet of lines	27
2.3. Projections codes and symbols	30
Self-check-2	33
Operation sheet2.1.....	34
Operation sheet2.2.....	34
LAP Test	35
Unit Three: Interpret technical drawing.....	37
3.1. Recognizing component assembly/object.....	38
3.2. Interpreting drawing codes and symbols	39
3.3. Interpreting dimensional tolerances.....	40
Self-check-3	43
Reference.....	45

Acknowledgment

Ministry of Labor and Skills wish to extend thanks and appreciation to the many representatives of TVET instructors and respective industry experts who donated their time and expertise to the development of this Teaching, Training and Learning Materials (TTLM).

Acronym

CAD	Computer Aided Design).
LAP	Learning Activity Performance
SP	<i>Station point</i>
PP	<i>.Picture plane</i>
VP	<i>vanishing point</i>

Introduction to the Module

One of the best ways to communicate one's ideas is through pictures, graphic illustration or drawings. Details of engineering innovations and technical inventions are hid in drawing for the purpose of safeguarding them. Technical/engineering drawing is a means of communicating shapes, sizes, positions and proportion, features and precision of physical objects.

This module is designed to meet the industry requirement under the automotive mechanics occupational standard, particularly for the unit of competency: **interpreting working drawings and sketches.**

This module covers the units:

- Identifying technical drawing
- Views, standard symbols and lines
- Interpret technical drawing

Learning Objective of the Module

- Identify technical drawing
- Identify views, standard symbols and lines
- Interpret technical drawing

Module Instruction

For effective use this modules trainees are expected to follow the following module instruction:

1. Read the information written in each unit
2. Accomplish the Self-checks at the end of each unit
3. Perform Operation Sheets which were provided at the end of units
4. Do the “test” giver at the end of each unit and
5. Read the identified reference book for Examples and exercise

1. Unit one: Identifying technical drawing

This unit is developed to provide you the necessary information regarding the following content coverage and topics:

- Introduction to technical drawing
- Identifying materials and dimensions
- Free hand sketch
- Checking and validating drawing

This unit will also assist you to attain the learning outcomes stated in the cover page.

Specifically, upon completion of this learning guide, you will be able to:

- Overview to technical drawing
- Identify materials and dimensions
- sketch free hand
- Check and validate drawing

1.1. Identify technical drawing

Introduction Technical Drawings are the graphics and documentation (notes and specifications) used by manufacturers to fabricate electronic and mechanical products, and by construction professionals to produce architectural structures (houses and buildings) and civil engineering projects (roads, dams, bridges).

Other terms often used to describe the creation of technical drawings are:

- ✓ drafting,
- ✓ engineering graphics,
- ✓ engineering drawings, and
- ✓ CAD (Computer Aided Design).

Technical drawing is not a new concept, there is archeological evidence suggesting that humans first began creating crude technical drawings several thousand years ago. Through the ages, architects and designers, including Leonardo Da Vinci, created technical drawings. But a French mathematician named Gaspard Monge is considered by many to be the founder of modern technical drawing. Monge's thoughts on the subject, Geometry Descriptive (Descriptive Geometry), published around 1799 became the basis for the first university courses. The first English-language text on technical drawing, Treatise on Descriptive Geometry, was published in 1821 by Claude Crozet, a professor at the United States Military Academy.

Aim of drawing

The main purpose of engineering drawings is to communicate to other engineers, machinists, etc. Drawings do the communication best merely because a picture is worth a thousand words. Giving all of the information needed to make the product and being accurate in that information is the main goal. Engineers are very picky about their drawings and must pay attention to detail.

Types of drawing and views

There are terms commonly associated with graphic and engineering design drawings in various forms and are meant to express different ideas as indicated below:

Diagram: This type of drawing depicts the function of a system represented in drawing form

Sketching: This generally refers to freehand drawing without the aid of drawing instrument

Drawing: This term usually means using instruments or drawing aids ranging from compasses to computers to bring precision to an expressed conception in form of graphics.

Drawing list: This is the list of cross references drawings that all combined to produce an single product

Parts list (bill of materials): Part listing in drawing shows material, number/quantity and provides reference number of various components

Assembly drawing: This shows how an individual parts are combined, refers to parts list

Design layout drawing: This represents broad principles of feasible solution

Arrangement drawing: This type of drawing shows finished arrangement of assemblies, including functional and performance requirements

Detail drawing: This is a single part drawing containing all information for fabrication. When there is a great disparity between feature sizes, or views are overcrowded with dimensions, a detail view can be used to capture the feature(s) of interest and display them in a removed view of greater scale.

1.2. Identifying materials and dimensions

Introduction Technical drawings must be prepared in such a way that they are clear, concise, and accurate. In order to produce such drawings equipment (i.e. materials and instruments) are used.

In this chapter, the different types of drawing instruments and materials and their uses will be discussed.

Selection of Drawing Materials The basic drawing materials which are necessary to prepare a technical drawing are:

- ✓ Drawing paper
- ✓ Drawing pencil
- ✓ Drafting or masking tape
- ✓ Eraser and erasing shield
- ✓ Rapidography

Drawing Papers Drawing papers are the materials on which the drawings are made. Depending on its application different types of drawing papers are available. These are: white plain paper profile paper, plan/profile paper, cross-section paper and tracing paper

Table 1 Paper and frame sizes for A-series

Designation	Paper frame size (mm)	Border width (mm)		Drawing frame size (mm)		Applications
		Left and right	Top and bottom	Width	Height	
A ₀	841 X 1189	28	20	1133	801	Technical drawings, posters
A ₁	594 X 841	20	14	801	566	Drawings, diagrams and large tables
A ₂	420 X 594	14	10	566	400	
A ₃	297 X 420	10	7	400	283	Letters, magazines, catalogs...
A ₄	210 X 297	7	5	283	200	
A ₅	148 X 210					Note pads

Drawing Pencils one of the most important drawing materials is the drawing pencil. The two types of pencils used in drawing are mechanical and wooden pencils (see Fig.1). Wood should be removed and the lead should be sharpened. To get good quality of line the pencil should be sharpened properly which means the lead should not be too sharp as it may pierce the paper and if it is too dull the line will be thick and accuracy will go down.

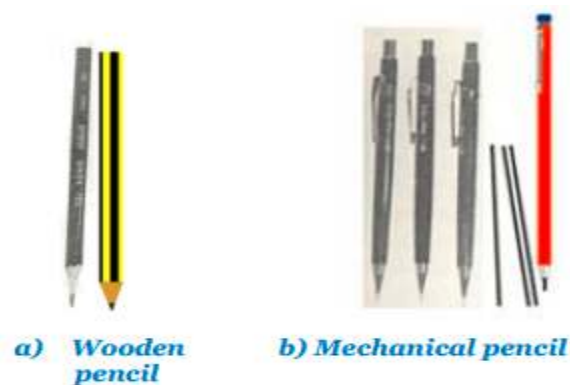

figure 1.1pencil

Figure 1.2 Drawing Pencils



Figure 1.3 pencil tip size



Too sharp



Acceptable



Too dull

Figure 1.4 pencil sharpening

Drafting or Masking Tape Before starting drawing, it is a common practice to attach the drawing paper to the drawing board in order to avoid unnecessary errors due to misalignment. Drafting tape is used for attaching the paper to the drawing board. Thumbtacks can also be used for fixing the paper to the drawing board. However, their use is not recommended because they have the tendency to affect the smoothness of the drawing board. Typical type of drafting tape is shown in Fig.4



Figure 1.5 masking tape

Eraser and Erasing Shield In the process of making a drawing, corrections and changes may be required. To do so, erasers are used to clean unnecessary line works. An erasing shield restricts the erasing area so that the correctly drawn lines will not be disturbed during the erasing procedure.



Figure 1.6 Eraser

Eraser shield

Rapidograph is a type of drawing pen by which lines are drawn on tracing papers. It produces light resistant, waterproof, precise and consistent ink lines for any application. Since most rapidograph pens require different pen sizes (line widths) for various projects, they are manufactured in different sizes.



Figure 1.7 Rapidograph

2.3 Selection of Drawing Instruments

The list of main drawing instruments is shown below:

- | | |
|---------------------|-----------------|
| 1. Drawing board | 7. Protractor |
| 2. Dusting brush | 8. French curve |
| 3. Templates | 9. French curve |
| 4. Pencil sharpener | 10. T-Square |
| 5. Scale | 11. Divider |
| 6. Set square | 12. Compass |

Drawing Board Drawing boards are usually made of white pine, but are sometimes made of other soft woods. The drawing surface may be the tabletop itself or a separate board. In both cases, the working surface (the drawing surface) should be flat, smooth and firm. For this reason, the working surfaces of drawing boards or table tops are made of soft white pine or basswood.



a) Drawing tables



b) Drafting machine



c) Portable drawing board



d) Tracing table

Figure 1.8 different types of drawing table

Drawing Templates A template is a thin and flat piece of plastic containing various cutout shapes. It is designed to increase the speed and accuracy of the drafter. Templates are available for drawing geometric shapes.

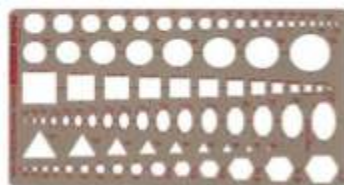
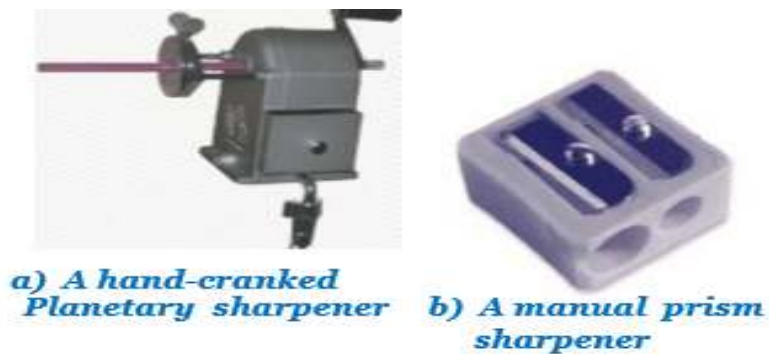
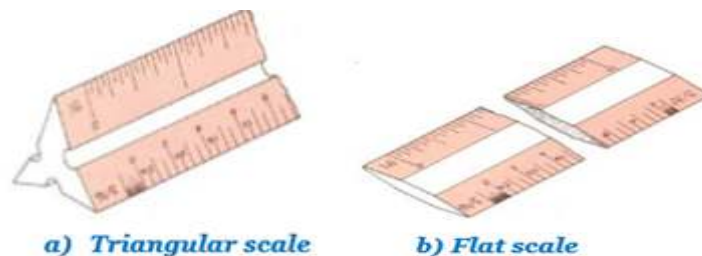

Figure 1.9 drawing template

Pencil Sharpeners Pencil sharpeners are drawing instruments used for sharpening pencils and they may be operated manually or by an electric motor and therefore a mechanical pencil sharpener is hand-powered.



Scales is an item of drawing instrument that has been carefully graduated (marked) and calibrated (labeled) in convenient increments for the user. Scales enable a user to make size reductions or enlargements rapidly and accurately. Scales are available in either flat or triangular shapes



Triangles (Set-squares) Triangles are sometimes called setsquares. The capability of rapidly producing straight lines on instrument drawings is provided by the 30-60 and 45 triangles.

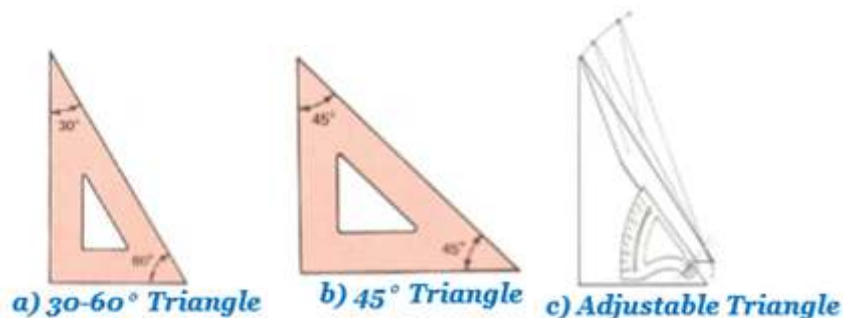

Protractor For measuring or setting off angles other than those obtainable with the triangles, the protractor is used. A typical protractor used for measuring angles is shown in Fig.1.10. You have most likely used this instrument in a geometry or trigonometry course.

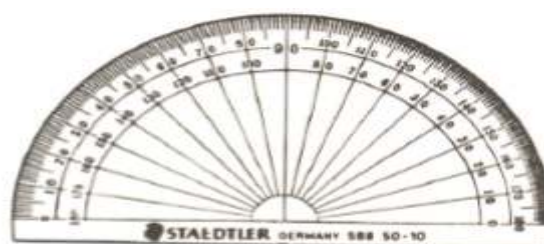

Figure 1.10 protractor

French Curve When it is required to draw mechanical curves other than circles or circular arcs, a French curve is generally employed. Many different forms and sizes of French curves are manufactured, as suggested by the more common forms illustrated in Fig.1.11

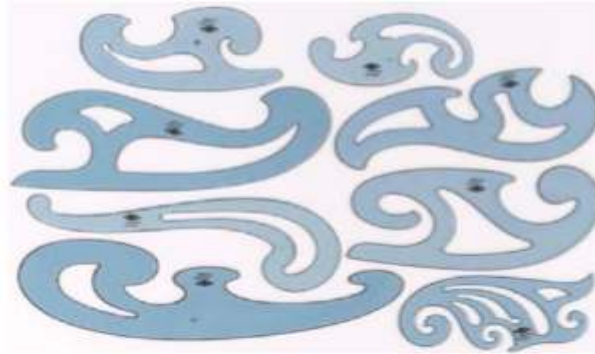
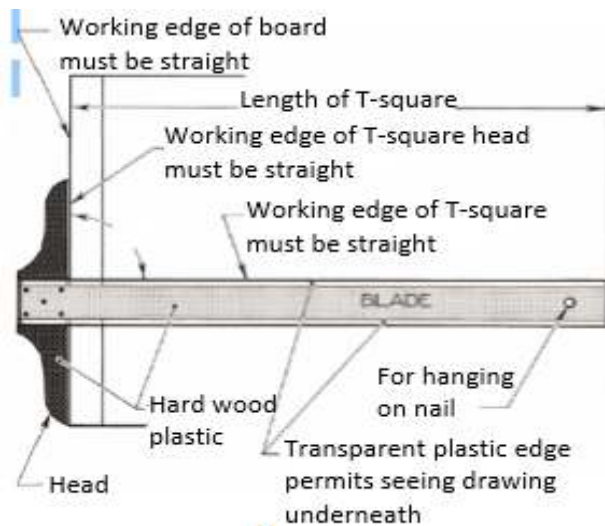
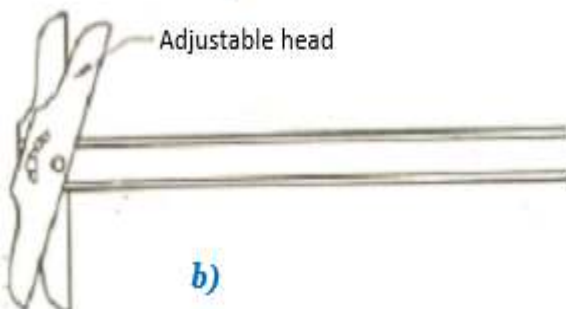

Figure 1.11 French Curve

T-Square Another important drawing instrument is the T-square. There are different types of T-squares as shown in Fig.1.12. The upper edge of a T-square and the inner edge of its head are called the working edges of the T-square. The working edges of a good T-square should be straight and right angle with each other. The common type of T-square is that shown in Fig. 1.12(a). Basically, the T-square is used to draw horizontal lines and to support or guide the set squares. However, T-squares such as shown in Fig.1.12 (b) and (d) can also be used to draw inclined lines because their heads are adjustable. The type shown in Fig.1.12 (c) is seldom used, perhaps because of the unusual design of the blade, but it has an advantage of rigidity.



a)



b)

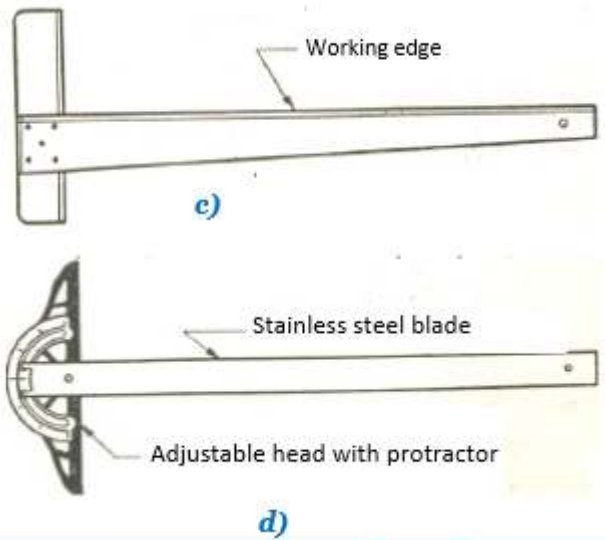

Figure 1.12 types of T-square

Divider A divider is a drawing instrument used for dividing distances into equal parts or for laying off a series of equal spaces. Dividers like shown in Fig.1.13 are designed to be operated with one hand and are used for making distances or transferring measurements. Specified measurements can be obtained from scales or another drawing and transferred to the drawing being prepared. Figure 1.13 illustrates how the dividers may be used to create a double sized drawing simply by transferring measurements, thus avoiding the necessity of measuring each length and doubling the measurement.



Figure 1.13 divider

Compass Compasses are used to draw circles and arcs. Depending on their application we can divide them into two, bow compass and beam compass as shown in Fig. below (a) and (b) respectively. The beam compass type is used for drawing circles and circular arcs larger than those made by the bow compass and for transferring diameters those are too great for the regular dividers.



a) Bow compass



b) Beam compass

1.3. Free hand sketch

Consider an Architect who wants to design a building, a Mechanical Engineer who wants to design a machine or a machine part; an Industrial Engineer who wants to design a plant layout; how would he/she start the design? Practically all starts and put their idea with freehand sketch. Freehand sketching is one of the most effective ways to communicate a pictorial or verbal idea to a workman. Sketching may be schematic, expressing new ideas, or instructional to convey ideas to draftsmen. After these ideas, concepts, and details for a project have been finalized, precise technical drawings are produced using instruments so that parts may be manufactured or constructed.

Types of Freehand Sketching

Freehand sketches can be categorized into three:

- a. Sketches which communicate technical data such as charts, graphs, maps, and diagrams as shown in Fig.1.14.

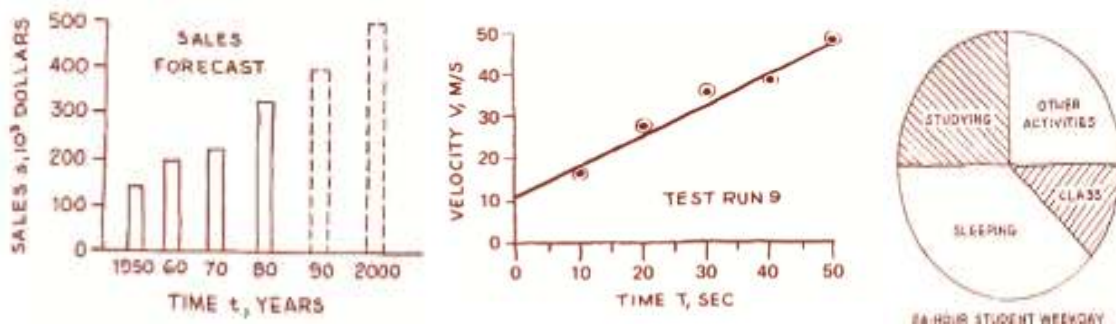

Figure 1.14 free hand sketch graph

- b. Sketches which illustrate two dimensions of an object such as a multi-view representation of an object as shown in Fig. 1.15.

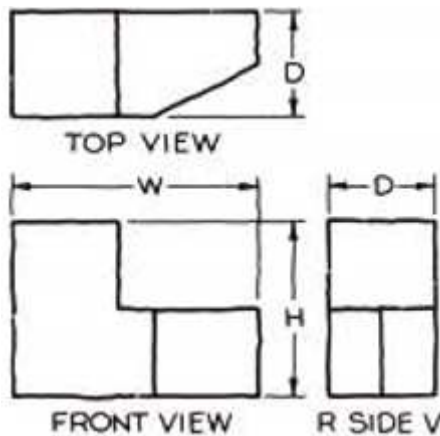

Figure 1.15 free hand sketch multi view

- c. Sketches which are two dimensional representations of three dimensional objects such as pictorial sketches of an object. See Fig. 1.16

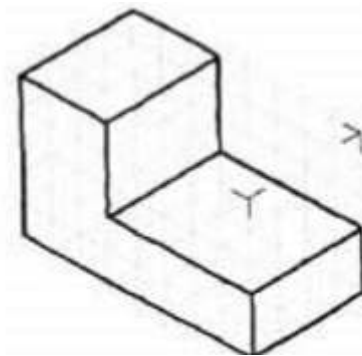

Figure 1.16 free hand sketch pictorial

1.4. Checking and validating drawing

Evaluation Guidelines Overall neatness:

- ✓ Lines are concisely drawn.
- ✓ Lettering is done to a high quality (all uppercase).
- ✓ Guidelines are fully erased to avoid confusion.

Drawing conforms to orthographic standards:

- ✓ Accuracy of drawing to actual object
- ✓ Alignment of views (top view above front view, for example)
- ✓ Correct use of symbols (fittings pointed away from or toward viewer)

Drawing conforms to isometric standards:

- ✓ Correct use of symbols (i.e., shoulders on fittings)
- ✓ Conformity to 30° planes
- ✓ Accuracy of drawing to actual project

Self-check-1

Directions: Answer all the questions listed below. Use the Answer sheet provided in the next page:

Choose the correct answer from the following Questions

1. _____ is a kind of technical drawing instruments used to prepare drawings
 - A. set squares
 - B. French curve
 - C. T-square
 - D. all

2. Which one is used to mark or measure angles between 0 and 180
 - A. Protractor
 - B. Divide

C. ellipse template

D. Circle Template

3. _____ is a thin, flat piece of plastic containing various cutout shapes

A. Template

B. French curve set squares

C. T-square

D. curve set squares

4. Which one of the following is the largest size of drawing sheets

A. A4

B. A0

C. A5

D. all

Note: Satisfactory rating - 5 points

Unsatisfactory - below 5 points

Answer Sheet

Score = _____

Rating: _____

Name: _____

Date: _____

True false Questions

1. _____

2. _____

3. _____

4. _____

Operation sheet-1.1

Operation title: Application of Basic Technical Drawing Equipment's

Purpose: To exercise how to draw on the drawing board

Instruction: Before starting the drawing you have to fulfill the following points:

- Make sure that all the necessary drawing instruments are ready and clean.
- Position your drawing board to minimize effects of shadows.
- Clean your drawing board.

Tools and requirement: Paper, Ruler, Pencil, Scale and drawing table

Steps in doing the task:-

1. Fixing Drawing Paper to the Board



a) *Place a paper close to the left edge of a table*



b) *Place a T-square and move the paper until its lower edge lies close to the top edge of a T-square*



c) *Align the top edge of the paper with T-square blade.*



d) *Attach the paper's corners with tape.*



e) *Move T-square down to smooth the paper*

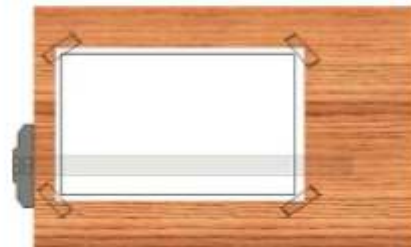

f) *Attach the remaining paper's corners with tape.*

2. Selecting Pencils
3. Sharpening Leads of Pencils and Compass
4. Drawing Horizontal Lines

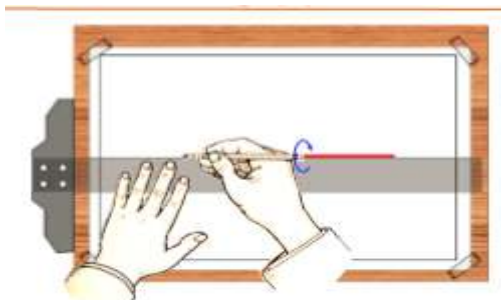

5. Drawing Vertical Lines

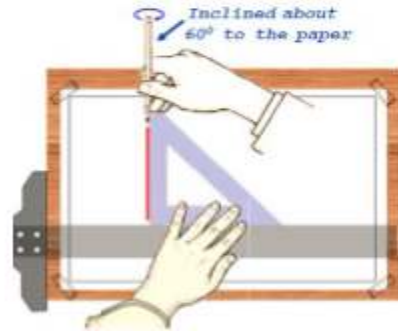

6. Drawing Inclined Lines

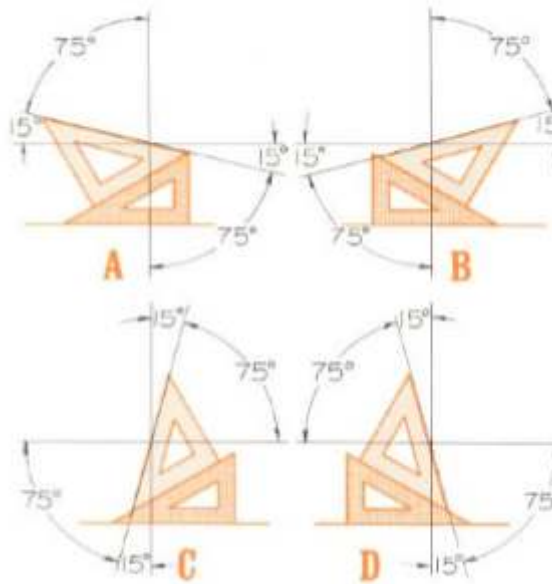

Quality Criteria: the given geometrical shape is measured with 1mm accuracy

Precautions: use proper material for proper use

Operation sheet 1.2

Operation title: Drawing Circles and Arcs

Purpose: To exercise how to draw on the drawing board

Instruction: Before starting the drawing you have to fulfill the following points:

- Make sure that all the necessary drawing instruments are ready and clean.
- Position your drawing board to minimize effects of shadows.
- Clean your drawing board.

Tools and requirement: Paper, Ruler, Pencil, Scale and drawing table

Steps in doing the task:-

- ✓ Draw two perpendicular center lines of the circle.
- ✓ Set off the required radius on one of the center lines.
- ✓ Place the needle point at the intersection point of the center lines.
- ✓ Adjust the compass to the required radius.
- ✓ Lean or incline the compass forward slightly.

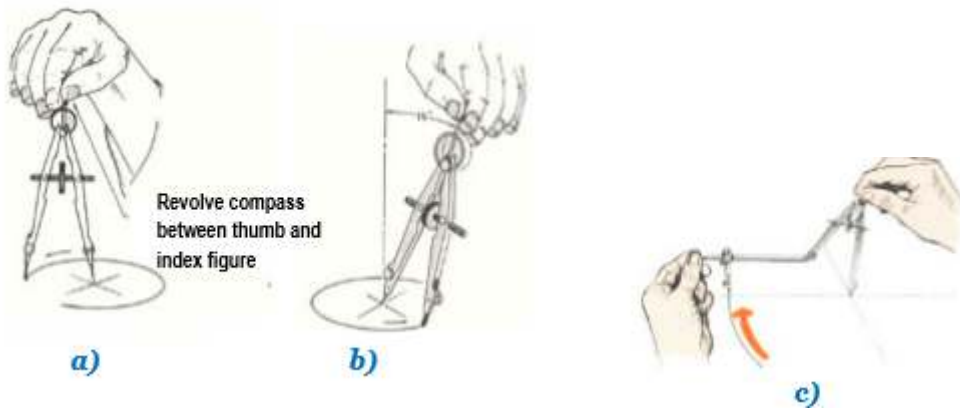

LAP Test	Practical Demonstration
----------	-------------------------

Name: _____

Date: _____

Time started: _____

Time finished: _____

Instruction I: Given necessary templates, tools and materials you are required to perform the following tasks within 5 hours

Task 1: Draw border line

Task 2: circle and arc

2. Unit Two: Identify views, standard symbols and lines

This unit to provide you the necessary information regarding the following content coverage and topics:

- Identifying Orthographic and isometric views
- Identifying and explaining alphabet of lines
- Projections codes and symbols

This guide will also assist you to attain the learning outcomes stated in the cover page.

Specifically, upon completion of this learning guide, you will be able to:

- Identify Orthographic and isometric views
- Identify and explaining alphabet of lines
- Identify Projections codes and symbols

2.1. Identifying Orthographic and isometric views

Orthographic Drawings Orthographic drawings are projections from a single angle. Most objects can be fully represented showing a front view, side view, and top (or plan) view. The biggest limitation of orthographic drawings is they represent a single perspective that may not show details hidden from view. For this reason, several views may have to be shown to indicate all details. Most commonly, front views and top views are shown.

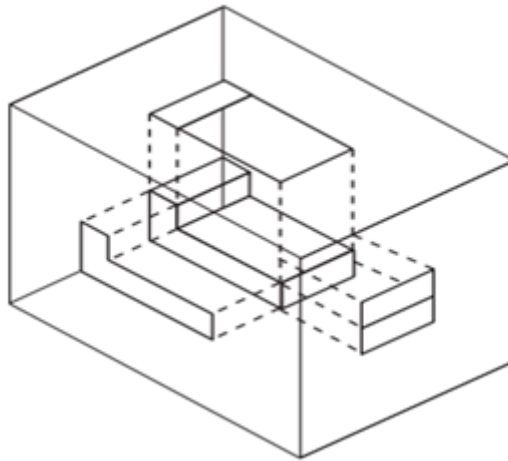

figure 2.1 orthographic drawing

Isometric Drawings Isometric drawings are most commonly used by tradespeople to communicate a large amount of information in a single drawing. Because isometric drawings show three sides of an object, they make it easy to visualize how a finished project may look or to better understand how the pieces will fit together. As demonstrated in the development of orthographic drawings, much more detail can be conveyed in a single isometric drawing than in a series of three orthographic drawings.

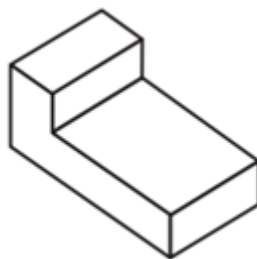

figure 2.2 Isometric drawings

2.1.1 PERSPECTIVE DRAWING

Page 24 of 46	Ministry of Labor and Skills Author/Copyright	Interpreting Working Drawings and Sketches	Version -1 September 2022
---------------	--	--	------------------------------

Perspective sketching A sketch that has been prepared in accordance with the concepts of perspective will present a somewhat more pleasing and realistic effect than one in oblique or axonometric. A perspective sketch actually presents an object as it would appear when observed from a particular point. In oblique and axonometric sketches, lines that are parallel on the actual object are sketched parallel. However, this is not the case in actual perception. For example, when we look at a long straight asphalt road of constant width, the road seems to be narrower and narrower as we look far away from us until it becomes a point at the horizon. If we look at a large building, it seems that the height of the building near to us is greater than that of its height away from us.

Similarly, if we look at electric poles of the same heights erected in a straight line, their heights seem to be decreasing until they disappear at the horizon. It is based on this observation that perspective sketches are defined. Therefore lines that are parallel on the actual object may become nonparallel on their perspective sketch. Fig. 2.3 shows a sketch of rail and electric poles, the point where all lines appear to meet is called the vanishing point. This vanishing point is located on a line referred to as the horizon line

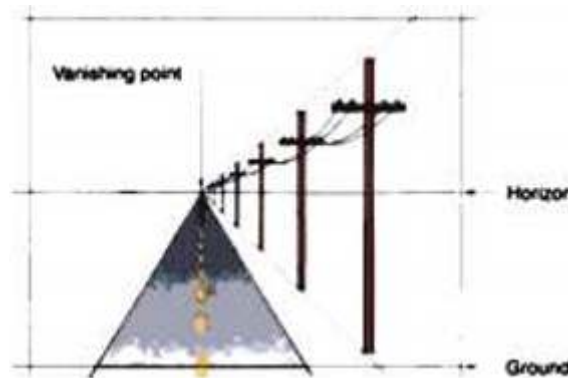

Figure 2.3 In a perspective sketch, all lines seem to disappear at the horizon

- Central projection is the other calling name.

It excels over all other types of projection in the pictorial representation of objects because it more closely approximates the view obtained by the human eye.

Terminology:

- ✓ The station of the observer's eye is called *Station point (SP)*.
- ✓ The imaginary plane of projection is called *Picture plane (PP)*.
- ✓ The point where all projection lines converge is called *vanishing point (VP)*.
- ✓ A horizontal line in the front view representing an infinite horizontal is called *Horizon*.

The *three* basic types of perspectives are:

I. One point – single vanishing point

Page 25 of 46	Ministry of Labor and Skills Author/Copyright	Interpreting Working Drawings and Sketches	Version -1 September 2022
---------------	--	--	------------------------------

- II. Two point – two vanishing point
- III. Three point – three vanishing point

2.1.2 Exploded view drawing

Exploded diagrams show how a product can be assembled and how the separate parts fit together, with dotted lines showing where the parts slide into place. The diagrams also show components that would usually be hidden in a solid drawing.

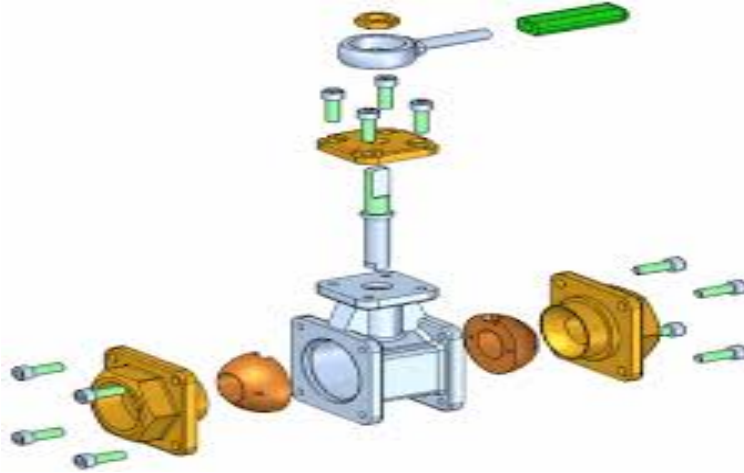

Figure 2.4 Exploded drawing

2.1.3 Hidden view technique

HIDDEN LINES consist of short, evenly-spaced dashes and are used to show the hidden features of an object (fig.2.5) You may vary the lengths of the dashes slightly in relation to the size of the drawing. Always begin and end hidden lines with a dash, in contrast with the visible lines from which they start, except when a dash would form a continuation of a visible line. Join dashes at corners, and start arcs with dashes at tangent points. Omit hidden lines when they are not required for the clarity of the drawing. Although features located behind transparent materials may be visible, you should treat them as concealed features and show them with hidden lines.

Hidden lines are used to show surfaces that are not directly visible. All surfaces must be shown in all view if an edge or surface is blocked from view by another feature, its drawn using a hidden line.

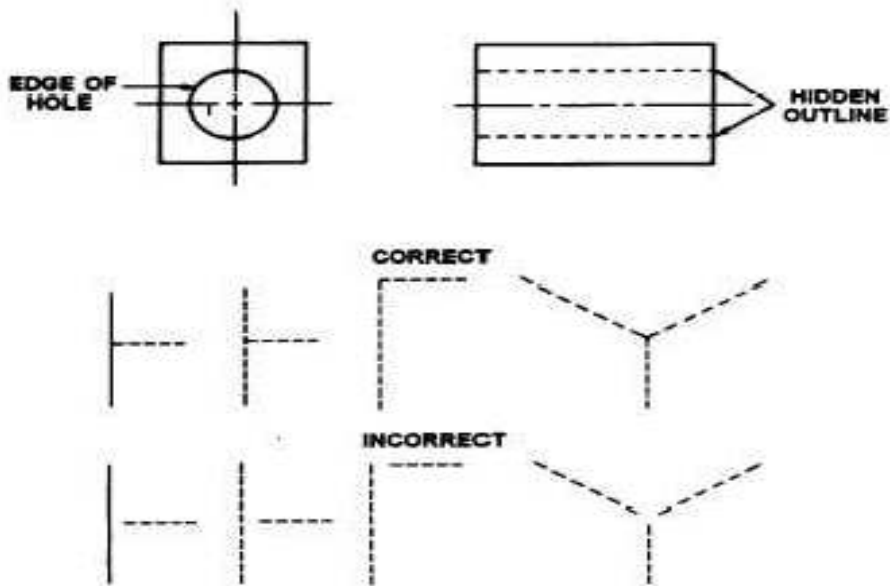

Figure 2.5 Hidden-line technique

2.2. Identifying and explaining alphabet of lines

The Language of Lines

- Object line
- Hidden line
- Section line
- Center line
- Dimension line
- Extension line
- Leader line
- Cutting plane line
- Break lines
- Phantom lines
- Border line

Object Line A *visible line*, is a thick continuous line, used to outline the visible edges or contours of an object.

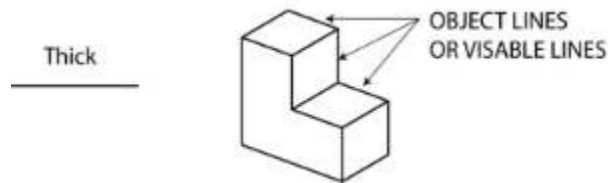

Hidden Line also known as a *hidden object line* is a medium weight line, made of short dashes about 1/8" long with 1/16" gaps, to show edges, surfaces and corners which cannot be seen. Sometimes they are used to make a drawing easier to understand. Often they are omitted in an isometric view.

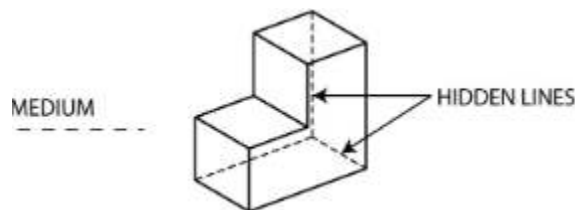

Section Line are used to show the cut surfaces of an object in section views. They are fine, dark lines. Various types of section lines may indicate the type of material cut by the cutting plane line.

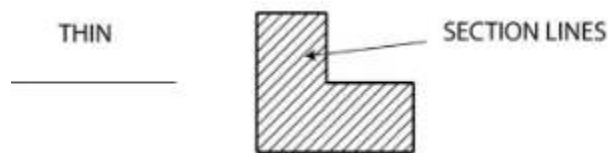

Center Line are used to indicate the centers of holes, arcs, and symmetrical objects. They are very thin (size), long-short-long kinds of lines.

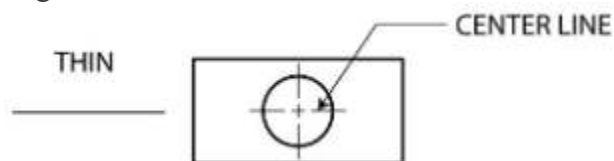

Dimension Line

Dimension lines are thin and are used to show the actual size of an object. There are arrowheads at both end that terminate at the extension lines.

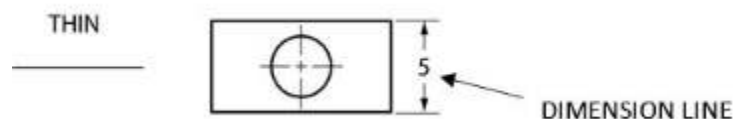

Extension Line

Extension lines are also thin lines, showing the limits of dimensions. Dimension line arrowheads touch extension lines.

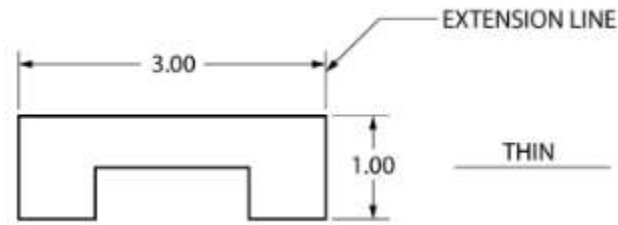

Leader Line

Leaders are more thin lines used to point to an area of a drawing requiring a note for explanation. They are preferably drawn at a 45° angles.

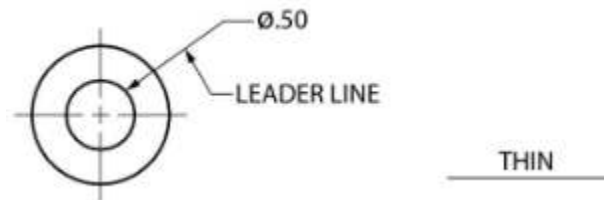

Cutting Plane Line

A cutting plane line (very heavy) helps to show the internal shape at a part or assembly by slicing through the object.

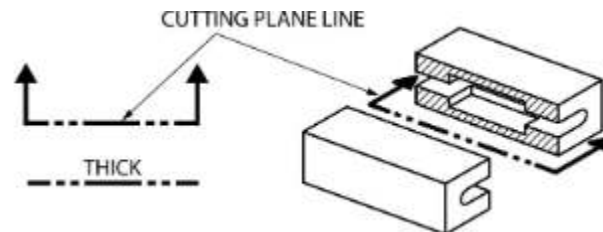

Break Line

There are three kinds of break lines used in drawings. They are used to remove, or 'break out' part of a drawing for clarity, and also to shorten objects which have the same shape throughout their length and may be too long to place on the drawing.

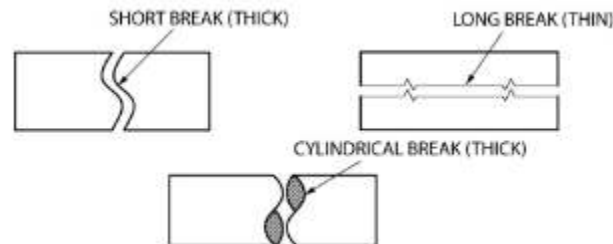

Phantom Line

Phantom lines are long-short-short-long lines most often used to show the travel or movement of an object or a part in alternate positions. It can also be used to show adjacent objects or features.

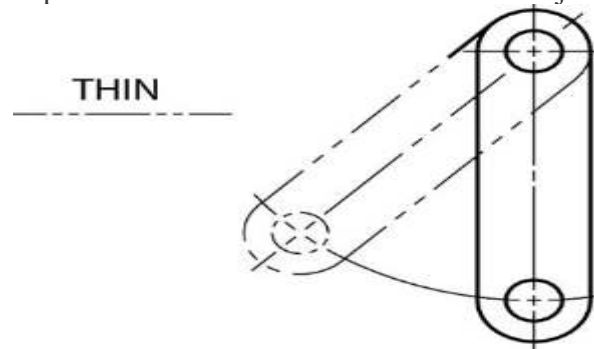

Border Line

Borderlines are very thick, continuous lines used to show the boundary of the drawing or to separate different objects drawn on one sheet. They are also used to separate the title block from the rest of the drawing.

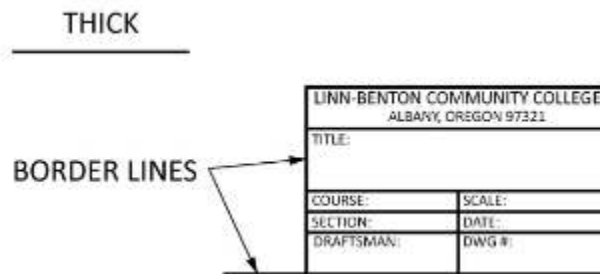

2.3. Projections codes and symbols

There are two types of projection systems in use today. These are:

- ✓ *Third-angle projection* is used in the United States, Canada, and in many other countries.
- ✓ *First-angle projection* is used mainly in Europe.

Basically their difference relies on the position of projection plane or imaginary projection plane or viewer's drawing paper.

First angle projection system:

Observer <=====> object <=====> Projection Plane

Here imagine that, the viewer is at left of the front view and looks at the object.

Note:

- ✓ Always top view will be placed below front view
- ✓ Always left side will be drawn on the right side of front view
- ✓ Always we place the right side to the left of the front view
- ✓ Bottom view will be shown above the front view

Symbolic representation of first angle orthographic projection is:

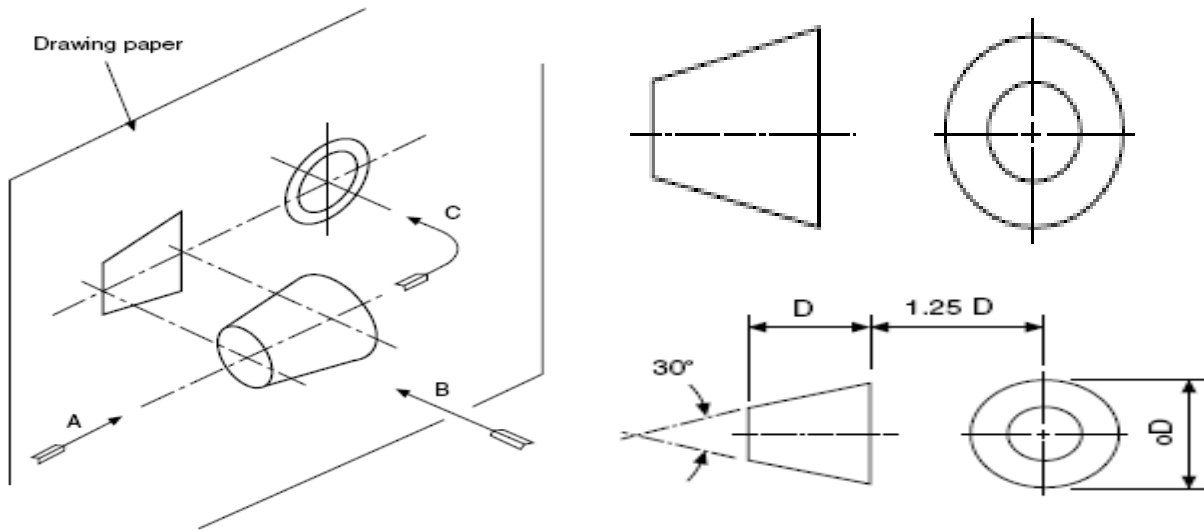

Example:

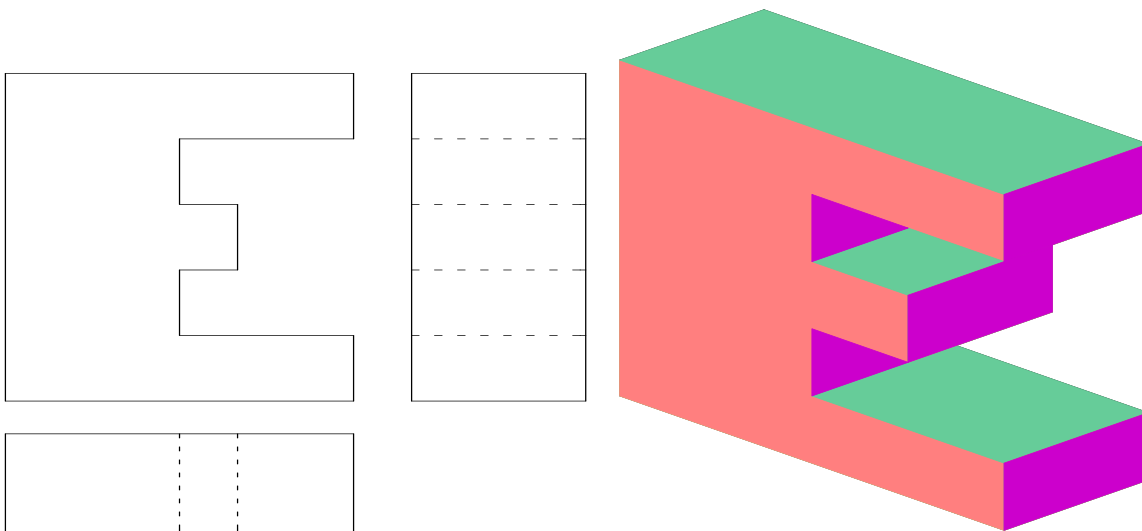

figure 2.6 First angle projection

Third angle projection system:

Observer <=====> Projection Plane <=====> object

Note:

- Top view is always projected above the front view
- The right hand side view is shown on the right hand side of the front view
- The left hand side view is shown on the left hand side of the front view

The standard symbolic representation for the third angle projection is:

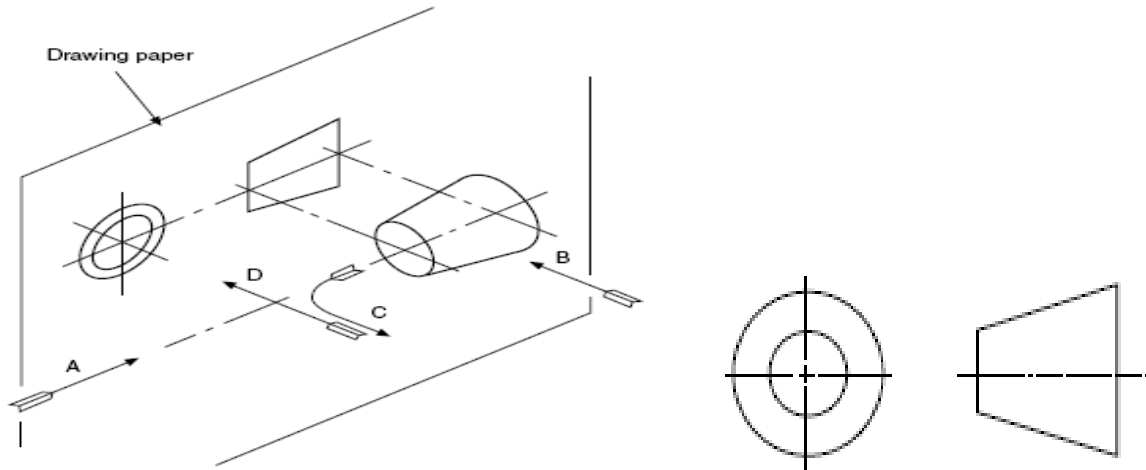

Examples:

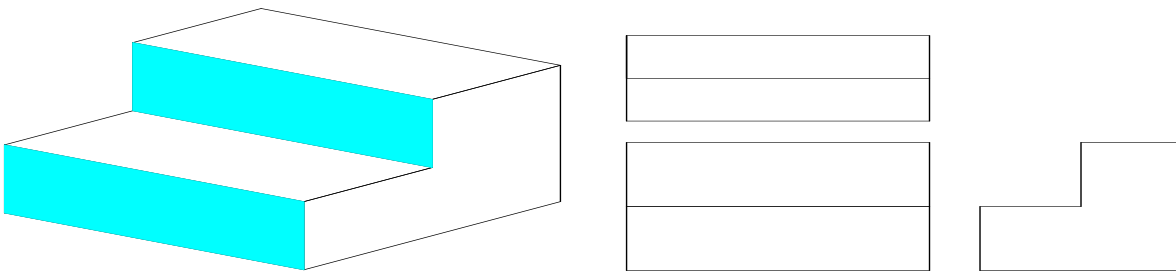
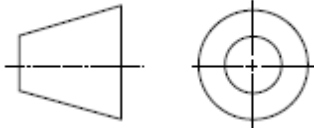
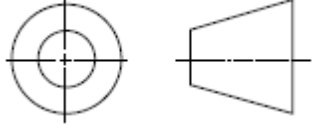

figure 2.7 third angle projection

Comparisons

FIRST ANGLE PROJECTION	THIRD ANGLE PROJECTION
<div style="display: flex; justify-content: space-around; align-items: center;"> <div style="border: 1px solid black; border-radius: 10px; padding: 5px; margin: 5px;">R.S.V</div> <div style="border: 1px solid black; border-radius: 10px; padding: 5px; margin: 5px;">F.V</div> <div style="border: 1px solid black; border-radius: 10px; padding: 5px; margin: 5px;">L.S.V</div> </div> <div style="border: 1px solid black; border-radius: 10px; padding: 5px; margin: 10px auto; width: 60px; text-align: center;">T.V</div>	<div style="border: 1px solid black; border-radius: 10px; padding: 5px; margin: 10px auto; width: 60px; text-align: center;">T.V</div> <div style="display: flex; justify-content: space-around; align-items: center; margin-top: 10px;"> <div style="border: 1px solid black; border-radius: 10px; padding: 5px; margin: 5px;">L.S.V</div> <div style="border: 1px solid black; border-radius: 10px; padding: 5px; margin: 5px;">F.V</div> <div style="border: 1px solid black; border-radius: 10px; padding: 5px; margin: 5px;">R.S.V</div> </div>
	

Self-check-2

Test-I

Direction write name the type of line shown below

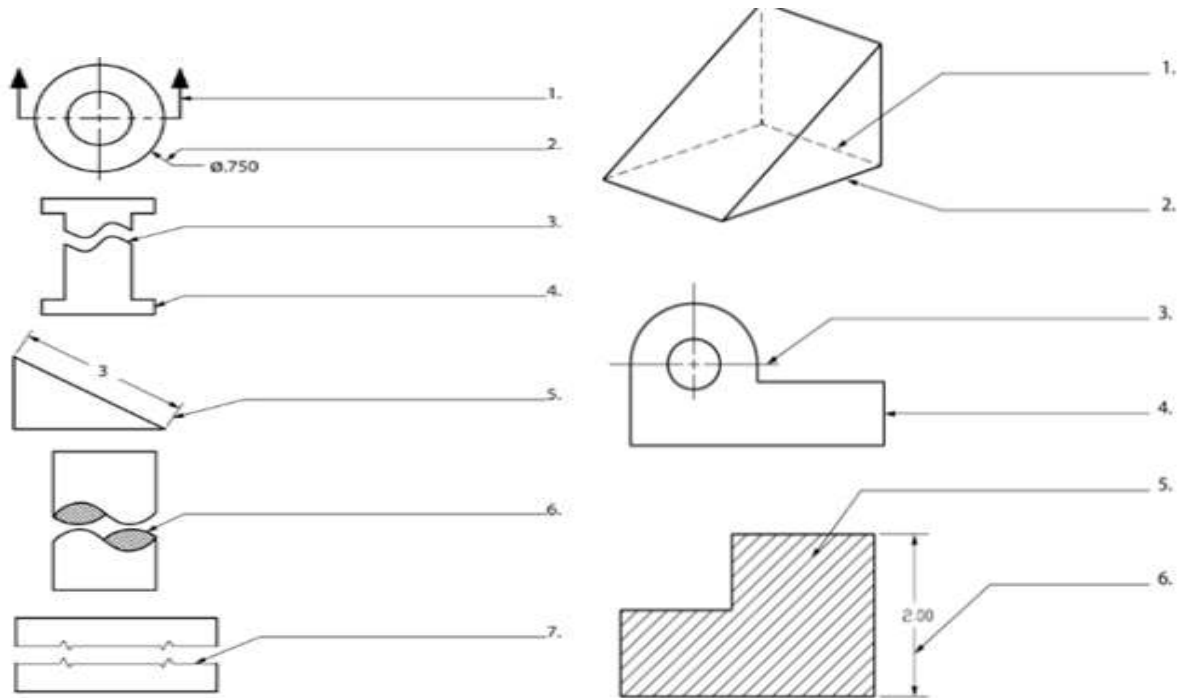

Direction:- draw and identify the lines needed to complete the figures as indicated

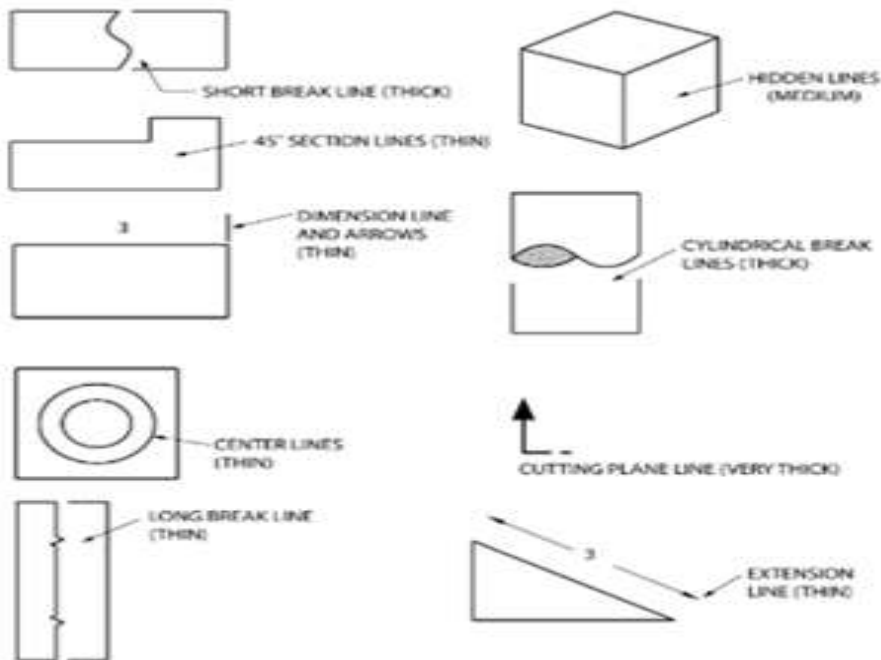

Operation sheet2.1

Operation title: Drawing first angle projection

Purpose: identifying the different projection

Instruction: Before starting the drawing you have to fulfill the following points:

- ✓ Make sure that all the necessary drawing instruments are ready and clean.
- ✓ Position your drawing board to minimize effects of shadows.

Tools and requirement: Paper, Ruler, Pencil, Scale and drawing table

Steps in doing the First angle projection task:-

- ✓ Object is kept in the first quadrant.
- ✓ Object lies between observer and the plane of projection
- ✓ The plane of projection is assumed to be non-transparent
- ✓ Front elevation view is drawn above the XY line
- ✓ Top plane view is drawn below the XY line
- ✓ Left view is projected on the right plane and vice versa

Quality criteria:-draw first angle projection in clear and net paper condition.

Precaution:-

Operation sheet2.2

Operation title: Drawing third angle projection

Purpose: identifying the different projection

Instruction: Before starting the drawing you have to fulfill the following points:

- ✓ Make sure that all the necessary drawing instruments are ready and clean.
- ✓ Position your drawing board to minimize effects of shadows.

Tools and requirement: Paper, Ruler, Pencil, Scale and drawing table

Steps in doing the First angle projection task:-

- ✓ Object is assumed to kept in the third quadrant.
- ✓ plane of projection lies between the observer and the Object
- ✓ The plane of projection is assumed to be transparent
- ✓ Front elevation view is drawn below the XY line
- ✓ Top plane view is drawn above the XY line
- ✓ Left view is projected on the right plane itself.

Quality criteria:-draw third angle projection in clear and net paper condition.

LAP Test	Practical Demonstration
-----------------	--------------------------------

Name: _____

Date: _____

Time started: _____

Time finished: _____

Instruction I: Given necessary templates, tools and materials you are required to perform the following tasks within 5 hours

Task 1: Drawing first angle projection

Task 2: Drawing third angle projection

3. Unit Three: Interpret technical drawing

This learning guide is developed to provide you the necessary information regarding the following content coverage and topics:

- Recognizing component assembly/object
- Interpreting drawing codes and symbols
- Interpreting dimensional tolerances

This guide will also assist you to attain the learning outcomes stated in the cover page.

Specifically, upon completion of this learning guide, you will be able to:

- Recognize component assembly/object
- Interpret drawing codes and symbols
- Interpret dimensional tolerances

3.1. Recognizing component assembly/object

Drawing recognition, which converts hand-drawn data into computer accessible codes, is one of the important branches in pattern recognition. Automatic assembly factories use 'assembly drawings', which inform the species of parts and the interconnections among the parts, to accomplish mechanical assembly tasks. Because there are complicated connection relations of parts in mechanical assembly drawings, recognition of assembly drawings is very difficult.

So far, some methods have been developed in order to recognize equipment location maps, network diagrams, electronic circuit diagrams, chemical plant engineering drawings.

- a. kami proposed a new template matching method which is very fast for binary images, this method, the image is shifted by specified distances instead of moving the template. Among the shifted images, logical operations are performed on the entire image area. These operations can be performed very quickly with the raster operation in a workstation.
- b. Macda developed the method of symbol recognition, according to the sequence of the following steps:
 - ✓ key constituent detection;
 - ✓ constituent detection;
 - ✓ symbol determination;
 - ✓ reclassification of remaining lines.
- c. Fahn presents a topology-based component extractor for the understanding of electronic circuit diagrams. These earlier systems don't utilize the semantic knowledge, what is expressed in the diagram. And this limits the possibility to improve recognition rate. It is not an easy task to make and modify software and symbol dictionaries, according to the types of the diagrams.

Assembly Drawing

An assembly working- drawing indicates how the individual parts of a machine or mechanism is assembled to make a complete unit.

An assembly drawing serves the following purposes:

- ✓ Describes the shape of the assembled unit.
- ✓ Indicates how the parts of the assembled unit are repositioned in relation to each other.
- ✓ Identifies each component that forms part of the assembled unit.

- ✓ Provides a parts list that describes and lists essential data concerning each part of the assembled Unit.
- ✓ Provides, when necessary, reference information concerning the physical or functional Characteristics of the assembled unit.

Assembly drawings may show one, two or three views to describe the assembled components; they must contain a parts list (may also be called material or cutting list depending on the engineering discipline), cross referencing (in balloons or circles), and general notes pertaining to the assembly.





3.2. Interpreting drawing codes and symbols

CODING

‘Coding’ is a recognized term used in technical drawing to describe the cross-referencing of parts of a drawing, either within the same sheet (i.e. relating an elevation to its place on the ground-plan) or from one sheet to another, often when details of a structure in an elevation need to be drawn in a bigger scale on a separate sheet. One could just call this ‘labeling’ in normal language, but as the name implies shorthand letter codes are used rather than words and it relies on everyone understanding how to read them. Using just letters and numerals rather than descriptive words has proven more effective in practice .. they take much less time to write, and they are more easily found and recognized!

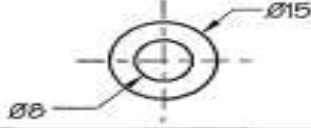
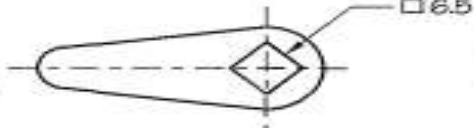
symbols

The symbols covered in on the following pages are an example of the widespread use of symbols and abbreviations in industry. The symbols and abbreviations covered in this module relate to a few trades and professions. In some areas there are so many symbols and abbreviations that only someone who is heavily involved would know them all. If you do not know what a symbol means, do not guess, because in some industries it could lead to a serious injury or death if a wrong interpretation or decision is made. If you do not know what a symbol means, make sure you ask someone who definitely knows, not someone who does not like to admit that they do not know. You do not want the guess of someone else, you want someone who definitely knows or someone who has the latest publication containing the symbols.

Feature	Symbol	Typical Application
Radius	R	
Diameter	∅	
Square	□	
Taper		
Slope		





Feature	Symbol	Typical Application
Feature identification		
Datum identification		
Equal	=	
First angle projection		
Third angle projection		

figure 3.1. symbol

3.3. Interpreting dimensional tolerances

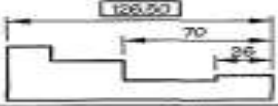
Interpreting dimensional *tolerances* and notation

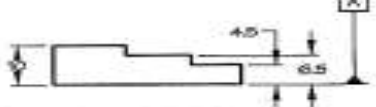
The purpose of dimensioning is to provide a clear and complete description of an object.

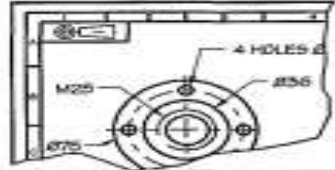
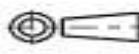
A Complete set of dimensions will permit only one interpretation needed to construct the

part.

Dimensioning should follow these guidelines.

- ✓ **Accuracy:** correct values must be given.
- ✓ **Clearness:** dimensions must be placed in appropriate positions.
- ✓ **Completeness:** nothing must be left out, and nothing duplicated.
- ✓ **Readability:** the appropriate line quality must be used or legibility

Type of tolerances.

2.1.1. General tolerance

If no tolerances are specified at the dimension level, then general tolerances may be applied by deliberately controlling the number of values past the decimal point on each dimension.

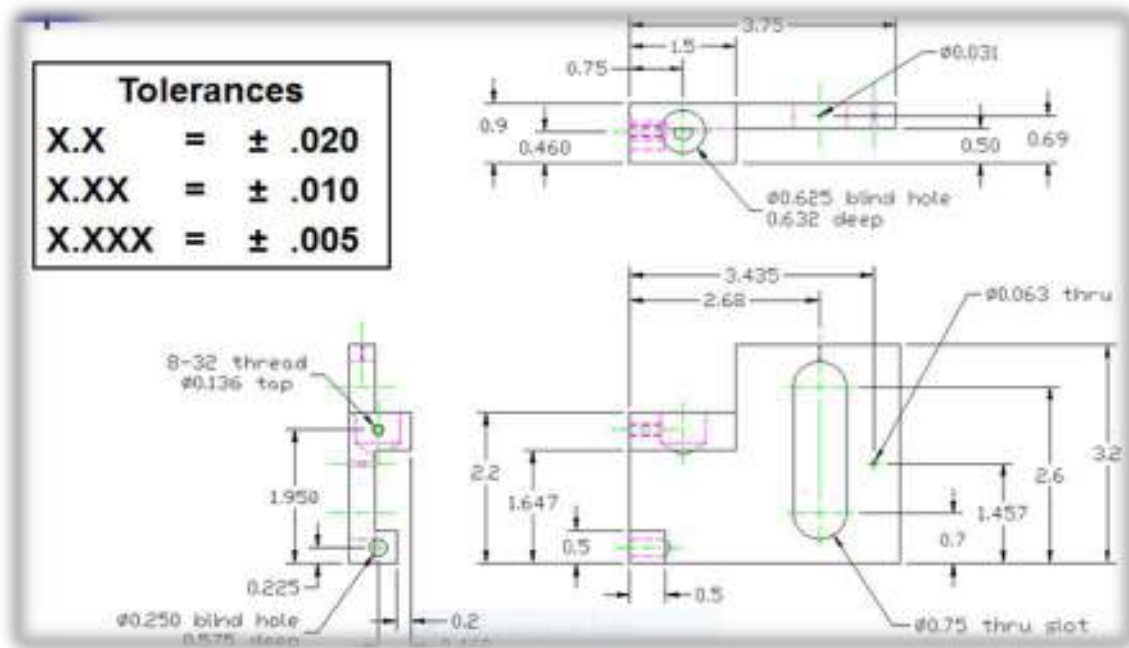

figure 3.2. general tolerance

No two manufactured objects are identical in every way. Some degree of variation will exist. Engineers apply tolerances to part dimensions to reduce the amount of variation that

occurs. The tolerance may be applied directly to the dimension or indicated by a general note located in the title block of the drawing A tolerance is an acceptable amount of dimensional variation that will still allow an object to function correctly

2.1.2. Angular tolerance

In a mechanical drawing of a part, angularity tolerance allows the designer to specify the degree to which the orientation of an angled part feature may vary.

The angularity symbol is often used to insure that the part can properly mate with another. In GD&T, the degree of permissible variation is not specified as a tolerance on the angle. Rather an indirect method is used where one specifies a tolerance zone at a specified angle from a datum, within which a part feature, axis, or center plane must lie.

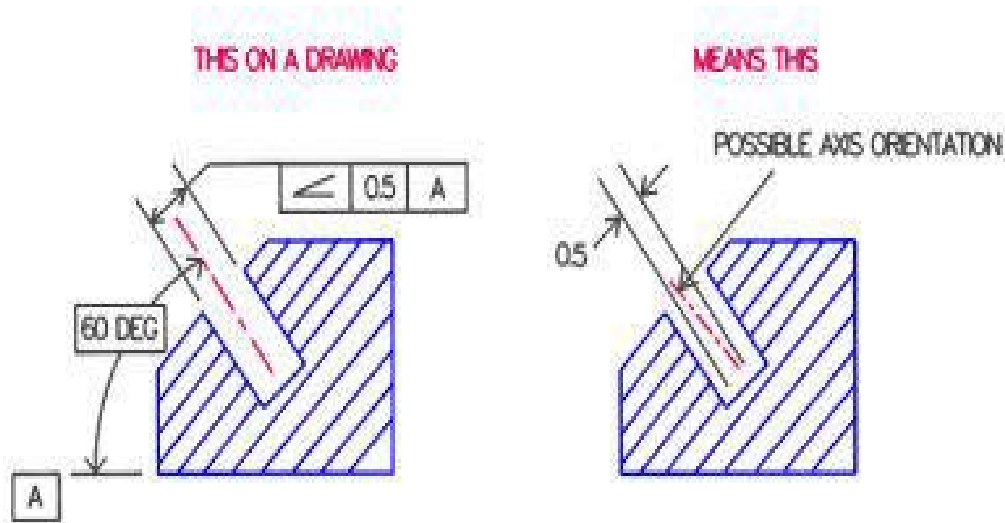

figure 3.3. Angular tolerances

In the left figure above, the boxed angularity symbol, tolerance and datum are used to control the center axis of an angled hole. The boxed symbols can be read “This axis must lie within two planes 0.5 apart , the planes inclined 60° to surface A”.

In the right figure above, the tolerance zone created is indicated by the parallel lines. This form of angularity tolerance applies only in the drawing view in which the tolerance is specified, and requires the permissible variation to be defined for other views. However, if a diameter symbol were placed in front of the boxed 0.5, this would create a cylindrical tolerance zone which would then apply to all drawing views.

Angularity is used in a tolerance stack when applied to a surface or line element. Angularity refines the orientation of the surface or line element, acting like a flatness control for the purposes of performing a tolerance stack

2.1.3. Geometric tolerance

In a typical engineering design and production environment, the designer of a part rarely follows the design to the shop floor, and consequently the only means of communication of the design intent are the design drawings.

Problems of validation and interpretation of design arise when the drawings do not clearly reflect what the designer intended, when they do not communicate to manufacturing how the design should be implemented and When the drawings are subjected to a number of different interpretations. The use of linear tolerances when dimensioning the part can control the size of a product. It is however possible for limits of size to be maintained while the shape of a part or feature deviates significantly from the intended form. To control this deviation, a method of specifying the acceptable tolerance of form is required and this is done using geometric dimensioning and tolerance symbols. These enable the designer to specify on the drawing, the geometry or shape of a component and they provide a precise definition of what constitutes a functionally good part.

Self-check-3

Name: _____ Date: _____

Directions: Answer all the questions listed below. Use the Answer sheet provided in the next page

Write true if the statement is correct write False if not correct

1. The purpose of dimensioning is to provide a clear and complete description of an object.
2. Complete set of dimensions will permit only different interpretation needed to construct the part.
3. Geometrical tolerances should be specify for all requirements critical to functioning and Inter changeability
4. Suitable locations on the part, called datum targets

Note: Satisfactory rating - 5 points

Unsatisfactory - below 5 points

Answer Sheet

Score = _____

Rating: _____

True false Questions

1. _____

2. _____

3. _____

4. _____

