

# Automotive Body Repair and Paint Work Level-II

Based on March 2022, Curriculum Version 1

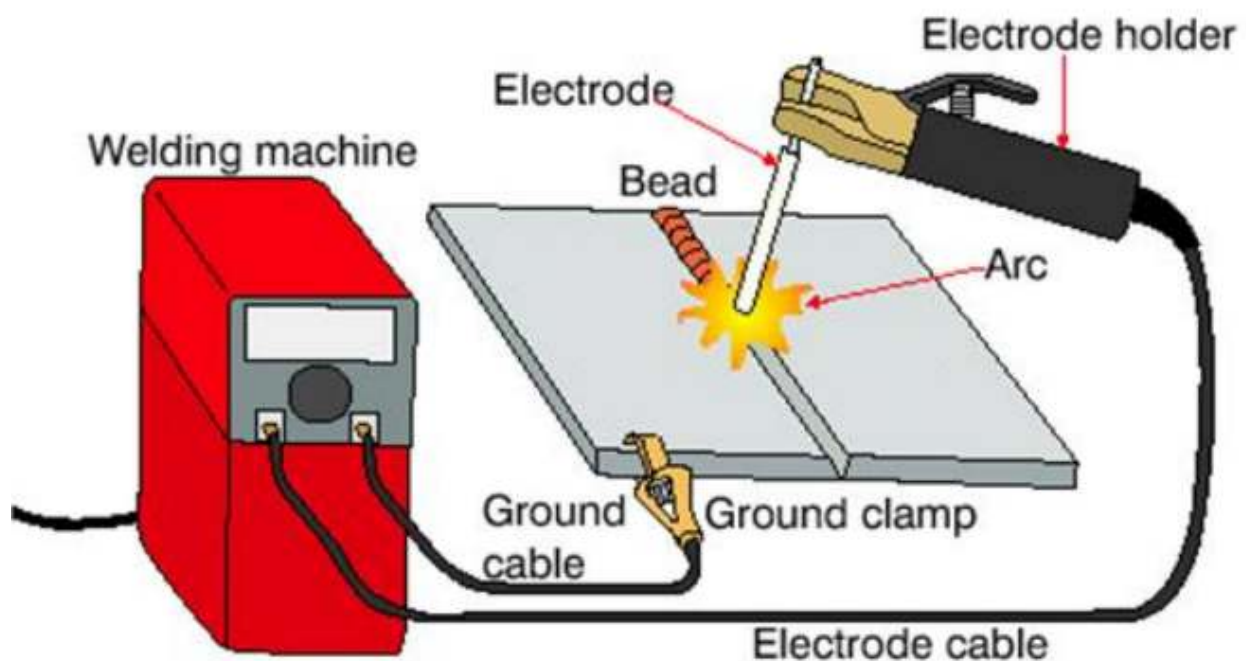

**Module Title: - Performing Metal Arc Welding**

**Module code: EIS BRP2 M06 0822**

**Nominal duration: 60Hour**

**Prepared by: Ministry of Labor and Skill**

**September 2022**

**Addis Ababa, Ethiopia**

## ACKNOWLEDGMENT

**Ministry of Labor and Skills** wish to extend thanks and appreciation to the many representatives of TVET instructors who donated their time and expertise to the development of this Teaching, Training and Learning Materials (TTLM).

## Acronym

MAW	Metal arc Welding
LAP test	Learning Activity Performance test
RWD	Rear Wheel Drive
CV joints	Constant Velocity joint
ECU	Electronic Control unit
PSI	Pascal esquire inch
TSB	Technical service bulletins

## TABLE CONTENT

ACKNOWLEDGMENT .....	2
Unit one: Plan and prepare welding work .....	6
1. Identifying welding requirements.....	6
1.1 Introduction to welding .....	6
1.1.1 Welding terminology .....	7
1.1.2 Manual metal arc welding (MMAW) .....	8
1.1.3 Application of Manual metal arc welding (MMAW) .....	9
1.1.4 Electricity and welding .....	9
1.1.5 General working principle of MMAW .....	9
2.1 Selecting Materials and appropriate welding equipment .....	10
2.2 Arc Welding Equipment .....	11
2.3. Other tools.....	13
Self check 1 .....	15
Unit Two: Perform MAW Welding.....	16
2.1 Apply OHS measures.....	16
2.1.1 Safety Recommendations for Arc Welding .....	16
2.1.2 Personal protective equipment (PPE) .....	17
2.1.3 Welding hazards and risks .....	18
2.1 Selected Electrodes .....	19
2.1.1 Setting up welding current .....	19
2.2.1 Material type .....	19
2.2.2 Welding slot forms.....	20
2.3 Preparing materials.....	22
2.3.1 Setting the work piece.....	23
2.3.2 Striking and maintaining an Arc .....	23
2.4 Carrying out welding.....	25
2.4.1 Procedures for arc welding .....	25
2.4.2 Welding joints.....	27
2.2.4 Welding positions .....	29
2.5 Cleaning welding seams.....	34
Self check 1 .....	36
Operation sheet 1     Setting up arc welding equipment.....	37
Operation sheet: 2 .....	38
LAP Test Practical Demonstration.....	39

Unit Three : Assure Quality and Clean Up.....	40
3.1 Inspecting welding seams .....	40
3.1.1 Welding Defects.....	40
3.2 Measuring joints.....	42
3.2.1 Inspection Tools and Measurements.....	42
3.2.2 Measuring joints and other defects .....	43
3.3 Cleaning and maintaining work area and welding equipment .....	45
3.3.1 Cleaning welding equipment and work area.....	45
3.3.2 Maintenance of equipment.....	45
Self check 1.....	46
Reference.....	47

## Introduction to the Module

This module covers the skills, attitudes and knowledge required in preparing the materials and carrying out routine Metal Arc Welding (MAW). It involves welding work plan and preparation, material selection and MAW welding.

**This module covers the units :**

- Plan and prepare welding work

- Perform MAW welding
- Assure quality and clean up

### Learning Objective of the Module

- Plan and prepare welding work
- Perform MAW welding
- Assure quality and clean up

### Module Instruction

For effective use this modules trainees are expected to follow the following module instruction:

1. Read the information written in each unit
2. Accomplish the Self-checks at the end of each unit
3. Perform Operation Sheets which were provided at the end of units
4. Do the “LAP test” giver at the end of each unit and
5. Read the identified reference book for Examples and exercise

### Unit one: Plan and prepare welding work

This unit is developed to provide you the necessary information regarding the following content coverage and topics:

- Identifying welding requirements
- Selecting materials and welding equipment

This unit will also assist you to attain the learning outcomes stated in the cover page. Specifically, upon completion of this learning guide, you will be able to:

- Identifying welding requirements
- Selecting materials and welding equipment

## 1. Identifying welding requirements

### 1.1 Introduction to welding

Welding is the process of joining together two pieces of metal so that bonding takes place at their original boundary surfaces. When two parts to be joined are melted together, heat or pressure or both is applied and with or without added metal for formation of metallic bond. The arc is struck between the electrode and the metal. It then heats the metal to a melting point. The electrode is then removed, breaking the arc between the electrode and the metal. This allows the molten metal to freeze or solidify. The arc is like a flame of intense heat that

is generated as the electrical current passes through a highly resistant air gap. There are various welding processes but commonly used types include the following:

- SMAW (Shielded Metal Arc Welding)
- GMAW (Gas Metal Arc Welding)
- GTAW (Gas Tungsten Arc Welding)

This level, SMAW/MMAW welding is to be discussed

**The basic conditions of welding quality to achieve products of such high quality includes the following:**

- No cracks or holes found in the bead.
- The bead has uniform waves, width and height.
- The finished product satisfies the design dimensions and has almost no distortion.
- The welding meets the required strength.

### 1.1.1 Welding terminology

**Electrode** – a rod that is used in arc welding to carry a current through a work piece to fuse two pieces together. In some welding processes, the electrode may also act as the filler metal.

**Filler metal** – metal deposited into the weld to add strength and mass to the welded joint.

**Flux** – a chemical cleaning agent that is applied to a joint just prior to the welding process to clean and protect the metal surface from surface oxides that form as a result of heating.

**Porosity** – the appearance of tiny bubbles on a weld bead as a result of gas entrapment; excessive porosity can weaken a weld.

**Root opening** – the separation at the joint root between the base metals.

**Shielding Gas** – inert or semi-inert gas that is used to protect the weld puddle and arc from reacting negatively with the atmosphere.

**Slag** – cooled flux that forms over the top of the weld; slag protects the cooling metal and is then chipped off. **Spatter** – liquid metal droplets expelled from the welding process.

**Weld ability** – the ability of a material to be welded under prescribed conditions and to perform as intended.

**Bead**- the weld/deposited melted metal

**Ripple** - Shape of the bead

**Pass** – Each layer of the weld bead deposited

**Crater** - Depression in the base metal

**Penetration** – Depth of fusion with metal

**Arc Length** – Distance from electrode to metal

**Weld Face** - Exposed surface of weld

**Root** - Base of weld

**Toe** - Where the face meets metal

**Leg** - Distance between toe and root

**Porosity** – Voids of gas pockets in the weld

**Post-Heating** – Heating after welding

**Pre-Heating** – Heating before welding

**Spatter** – Metal particles expelled during welding

**Weaving** – Back and forth movement

**Undercut** – Toe below metal surface

**Overlap** – Toe above metal surface

### 1.1.2 Manual metal arc welding (MMAW)

MMAW is a welding process that creates an electric arc between a hand held, flux-coated, consumable filler wire and the work piece. Welding commences when an electric arc is struck by making contact between the tip of the electrode and the work. The intense heat of the arc melts the tip of the electrode and the surface of the work close to the arc. Tiny globules of molten metal rapidly form on the tip of the electrode, then transfer through the arc stream into the molten weld pool. In this manner, filler metal is deposited as the electrode is progressively consumed. The arc is moved over the work at an appropriate arc length and travel speed, melting and fusing a portion of the base metal and continuously adding filler metal. Since the arc is one of the hottest of the commercial sources of heat [temperatures above 9000° F (5000° C) have been measured at its center], melting of the base metal takes place almost instantaneously upon arc initiation. If welds are made in either the flat or the horizontal position, metal transfer is induced by the force of gravity, gas expansion, electric and electromagnetic forces, and surface tension. For welds in other positions, gravity works against the other forces. The flux coating breaks down in the arc to produce a gaseous shield

### 1.1.3 Application of Manual metal arc welding (MMAW)

This also referred to as Stick Welding<sup>l</sup> is the most commonly used type of welding and used for everything from pipeline welding, farm repair and complex fabrication. It uses a stick<sup>l</sup> shaped electrode and thus its name indicates. Materials that can be welded by this process include: steel, cast iron, stainless steel, etc. This process Can also hard face with correct electrode.



### 1.1.4 Electricity and welding

This also referred to as —Stick Welding‖ is the most commonly used type of welding and used for everything from pipeline welding, farm repair and complex fabrication. It uses a —stick‖ shaped electrode and thus its name indicates. Materials that can be welded by this process include: steel, cast iron, stainless steel, etc. This process Can also hard face with correct electrode

**All welding processes depend on three main requirements for their operation. These are**

- A heat or energy source – needed for fusion.
- Atmospheric shielding – to prevent oxygen and nitrogen in the atmosphere from contaminating the weld.
- Filler metal – to provide the required weld build-up. •

### 1.1.5 General working principle of MMAW

The electrode is placed in an electrode holder, which is connected to one lug of a constant current welding power supply. This power supply can be operated on alternating current (AC), direct current electrode positive (DCEP), or direct current electrode negative (DCEN) depending on the type of electrode being used. A cable connected to the work is attached to the other lug. The machine is energized and the electrode is lightly touched to the work the arc is then initiated. The welder then manually moves the electrode along the weld joint. Thus, an electric arc will be created because of the resistivity of the air gap between metallic pieces what we are going to join. This arc causes the pieces to melt and join together.

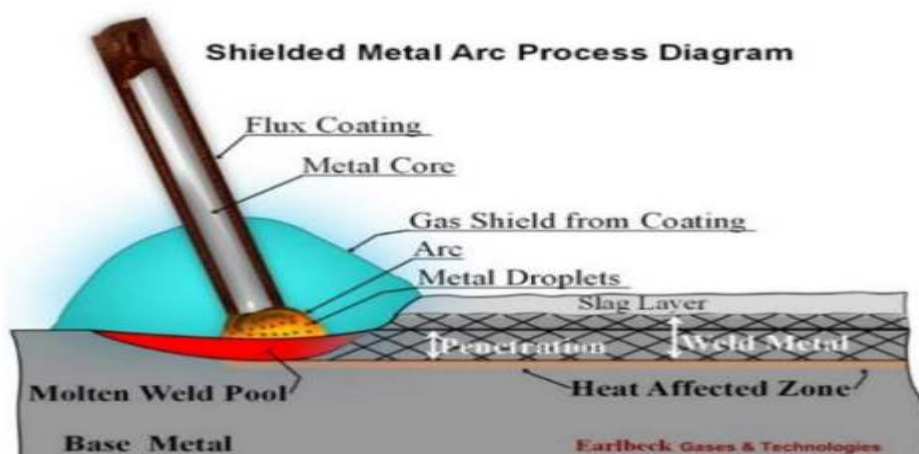

figure 1 1 manual metal arc welding diagram

## 2.1 Selecting Materials and appropriate welding equipment

SMAW dominates other welding processes in the maintenance and repair industry in particular. Although flux-cored arc welding is growing in popularity, SMAW continues to be used extensively in the construction of steel structures and in industrial fabrication. The process is used primarily to weld iron and steels, including stainless steel, but most alloys can be welded with this method.

When the steel composition is easily identifiable, retilite electrodes can be used as they are easier to strike and to weld and give a good-looking seam. In practice, welding of medium, high carbon steels ( $>0.25\%$ ) can cause the formation of structural defects; application of the electrode procedure is recommended mainly for welding medium to thick joints using basic electrodes: in these cases a high quality weld is obtained with good breakage resistance.

Steel pipe welding is carried out using cellulose electrodes, where high penetration and good electrode workability are required. Beveling is always recommended, with a bevel angle that is sufficient to allow almost complete electrode insertion into the welding gap. For special materials such as stainless steel, aluminum and its alloys, cast iron, specific electrodes for the particular material are used.

Stainless steels are welded with direct current (DC) with reverse polarity; special electrodes are used and are differentiated by the metallurgical composition of the material to be welded (presence of chrome (Cr) and of Nickel (Ni) in variable proportions).

Aluminum and light alloys are welded with direct current (DC) with reverse polarity. The machine should be equipped with rather a high strike dynamic to guarantee electrode strike. Also in this case special electrodes are used and are differentiated by the metallurgical composition of the material to be welded (presence of Magnesium (Mg) and of Silicon (Si) in variable proportions).

Cast iron is welded with direct current (DC) with reverse polarity; the majority of cast iron structures and machine members are obtained by casting, so that welding is used to correct possible casting defects or for repairs. Special electrodes are used and the base material should be heated sufficiently before use

## 2.2 Arc Welding Equipment

Arc welding equipment, setup and related tools and accessories are shown in Figure below. However some common tools of arc welding are shown separately through Figure. Few of the important components of arc welding setup are described as under.

### 1. Arc welding power source

Both direct current (DC) and alternating current (AC) are used for electric arc welding, each having its particular applications. DC welding supply is usually obtained from generators driven by electric motor or if no electricity is available by internal combustion engines. For AC welding supply, transformers are predominantly used for almost all Arc-welding where mains electricity supply is available. They have to step down the usual supply voltage (200-400 volts) to the normal open circuit welding voltage (50-90 volts). The following factors influence the selection of a power source:

Type of electrodes to be used and metals to be welded

- Available power source (AC or DC)
- Required output
- Duty cycle
- Efficiency
- Initial costs and running costs
- Available floor space
- Versatility of equipment

## 2. Welding cables

Welding cables are required for conduction of current from the power source through the electrode holder, the arc, the work piece and back to the welding power source. These are insulated copper or aluminum cables.

## 3. Electrode holder

Electrode holder is used for holding the electrode manually and conducting current to it. These are usually matched to the size of the lead, which in turn matched to the amperage output of the arc welder. Electrode holders are available in sizes that range from 150 to 500 Amps.

## 4. Welding Electrodes

An electrode is a piece of wire or a rod of a metal or alloy, with or without coatings. An arc is set up between electrode and work piece. Welding electrodes are classified into following types-

- (i) Consumable Electrodes Bare Electrodes
- (ii) Coated Electrodes
- (iii) Non-consumable Electrodes Carbon or Graphite Electrodes
- (iv) Tungsten Electrodes

Consumable electrode is made of different metals and their alloys. The end of this electrode starts melting when arc is struck between the electrode and work piece. Thus consumable electrode itself acts as a filler metal. Bare electrodes consist of a metal or alloy wire without any flux. This coating on melting performs many functions like prevention of joint from atmospheric contamination, arc stabilizers etc. Non-consumable electrodes are made up of high melting point materials like carbon, pure tungsten or alloy tungsten etc.

Note: In this level we are going to use consumable electrodes usually coated.

5. **Hand Screen** ;- used for protection of eyes and supervision of weld bead.

6. **Chipping hammer**;- is used to remove the slag by striking.

7. **Wire brush**;- is used to clean the surface to be weld.

8. **Protective clothing**;- Operator wears the protective clothing such as apron to keep away the exposure of direct heat to the body.

The following figures are used to describe the welding equipments and their configuration

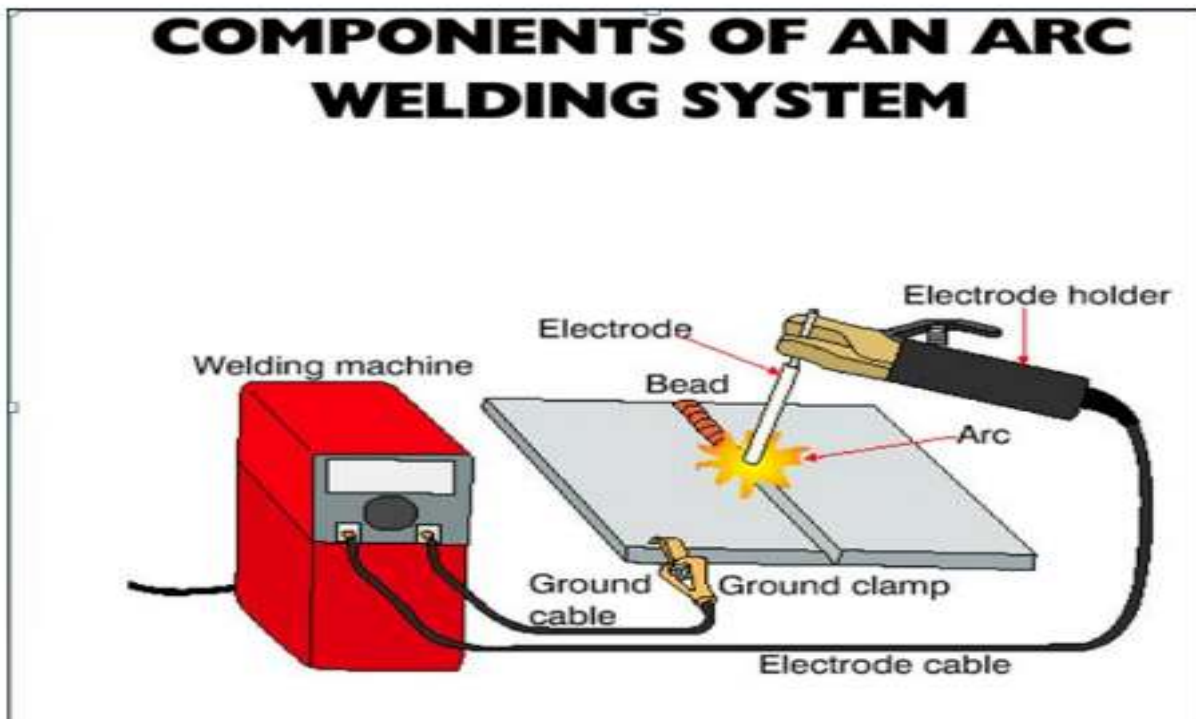

Figure 2.3: welding machine

### 2.3. Other tools

The following tools are commonly used in metal welding shops:

- Steel rule
- Try square
- Scriber
- Hacksaw
- Bench vice
- Flat file
- Face shield
- Tongs
- Wire-brush
- Chipping hammer
- Portable grinder

### Self check 1

Direction1: Short answer items Instruction1- Briefly answer the following questions

1. Mention materials that can be welded by MMA welding.
2. List the two types of power sources
3. List at least 5 components of a welding equipment.
4. Write the factors that can affect selection of power source for welding project?

### Unit Two: Perform MAW Welding

This unit to provide you the necessary information regarding the following content coverage and topics:

- apply OHS measures
- Setting up welding currency
- Preparing materials
- Carrying out welding

Page 15 of 47	Ministry of Labor and Skills Author/Copyright	<b>Performing Metal Arc Welding</b>	Version -1 September , 2022
---------------	--	-------------------------------------	--------------------------------

- Cleaning welding seams

This guide will also assist you to attain the learning outcomes stated in the cover page. Specifically, upon completion of this learning guide, you will be able to:

- Identify OHS measures
- Setting up welding currency
- Preparing materials
- Carrying out welding
- Cleaning welding seams

## 2.1 Apply OHS measures

To achieve safe working conditions in the metal fabrication and welding industry, all personnel should be able to recognize the hazards which apply to their particular occupation. Welding operators must also know the correct operating procedures for the equipment. An operator can be subjected to many safety hazards associated with the industry. As with any other industrial worker, they may be injured through incorrect lifting practices, falling or tripping, or incorrect use of hand tools and machines. The operator will also encounter particular hazards associated with welding. A clean, tidy workplace, free from combustible materials, is an essential requirement for the safety of welding personnel. Additionally, others working in the vicinity of welding operations are at risk from hazards such as electrocution, fumes, radiation, burns or flying slag and noise. They too must be protected if their health and safety is not to be put at risk.

### 2.1.1 Safety Recommendations for Arc Welding

The beginner in the field of arc welding must go through and become familiar with these general safety recommendations which are given as under.

1. The body or the frame of the welding machine shall be efficiently earthed. Pipe lines containing gases or inflammable liquids or conduits carrying electrical conductors shall not be used for a ground return circuit. All earth connections shall be mechanically strong and electrically adequate for the required current.
2. Welding arc in addition to being very hot is a source of infra-red and ultra-violet light also; consequently the operator must use either helmet or a hand-shield fitted with a special filter glass to protect eyes.
3. Excess ultra-violet light can cause an effect similar to sunburn on the skin of the welder..

Page 16 of 47	Ministry of Labor and Skills Author/Copyright	<b>Performing Metal Arc Welding</b>	Version -1 September , 2022
---------------	--	-------------------------------------	--------------------------------



4. The welder's body and clothing are protected from radiation and burns caused by sparks and flying globules of molten metal with the help of the following:
5. Gloves protect the hands of a welder.
6. Leather or asbestos apron is very useful to protect welder's clothes and his trunk and thighs while seated he is doing welding.
7. For overhead welding, some form of protection for the head is required
8. Leather skull cap or peaked cap will do the needful.
9. Leather jackets and leather leggings are also available as clothes for body protection.
10. Welding equipment shall be inspected periodically and maintained in safe working order at all times.
11. Arc welding machines should be of suitable quality.
12. All parts of welding set shall be suitably enclosed and protected to meet the usual service conditions

### **2.1.2 Personal protective equipment (PPE)**

Arc welding, like most welding processes, requires operators to protect themselves from the radiated heat and rays associated with the process. Perhaps the most efficient way of doing this is by the wearing of protective clothing. The use of all protective clothing is dictated by the nature of the work and the comfort of the operator.

Page 17 of 47	Ministry of Labor and Skills Author/Copyright	<b>Performing Metal Arc Welding</b>	Version -1 September , 2022
---------------	--	-------------------------------------	--------------------------------

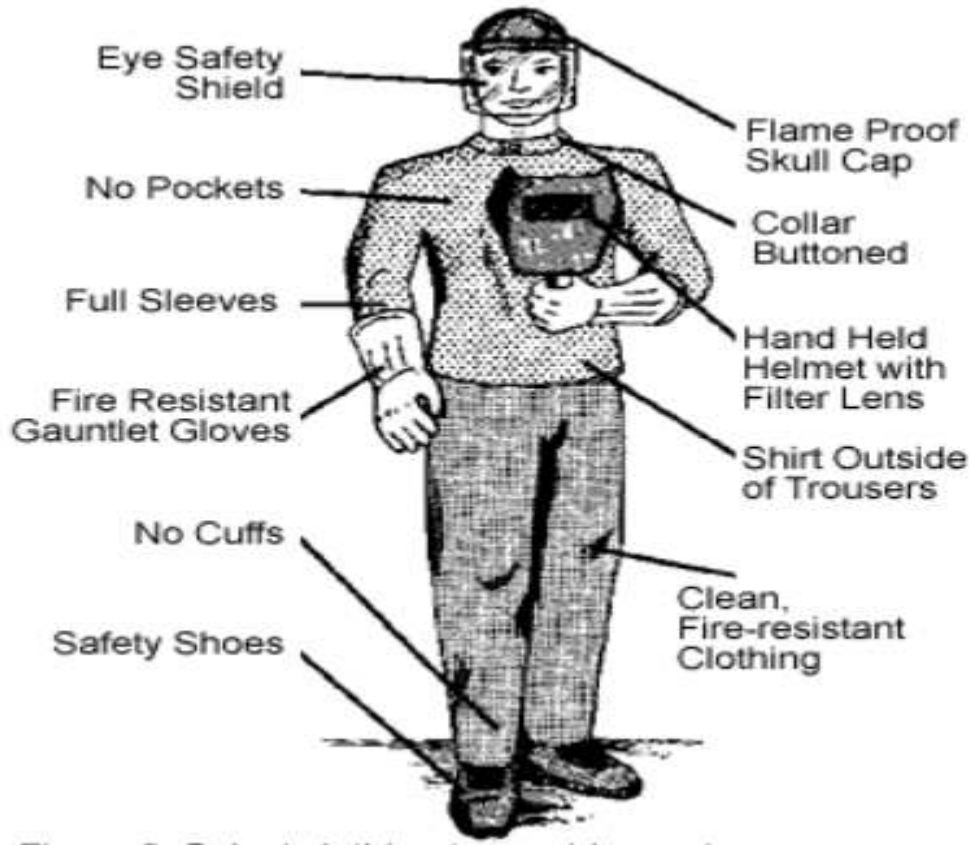



### 2.1.3 Welding hazards and risks

The hazards in manual electric arc welding operation can be broadly grouped into the following major categories:

- A. Fire and explosion hazards;
- B. Electrical hazards;
- C. Physical hazards;
- D. Respiratory hazards; and
- E. Other related hazards.

**Table 1.1 Potential health & safety hazards signs**

<b>EXPOSURE</b>		Understand the chemical(s) you are working in the vicinity of. Consult the MSDS and wear the appropriate PPE.
<b>UV Light</b>		Ensure you are taking safety means to protect yourself from UV rays while welding
<b>FOOT INJURY</b>		Approved protective footwear is needed when there is the risk of foot injury due to slipping, uneven terrain, abrasion, crushing potential, temperature extremes, corrosive substances, puncture hazards, electrical shock and any other recognizable hazard

<b>COMPRESSED GASES</b>		Do not <ul style="list-style-type: none"> <li>• drop</li> <li>• keep near heat</li> </ul>
<b>FIRE</b> Due to flammable liquids, gases or combustible dusts		Ensure that your work area is clear of combustible materials that could start a fire as a result of welding sparks.
<b>FOOT INJURY</b> Falling objects		The appropriate ASTM or CSA approved footwear must be worn when job hazard analysis shows it is needed.

## 2.1 Selected Electrodes

Welding electrodes in electric arc welding, the term electrode refers to the component that conducts the current from the electrode holder to the metal being welded. Electrodes are classified in to two major groups: consumable and non-consumable.

### 2.1.1 Setting up welding current

The welding quality of the shielded metal arc welding is determined by the welding parameters / characteristics including the welding slot forms, electrode diameter, welding current, welding speed, arc length, electrode advance angle, electrode oscillation angle and movement, welding direction and position, etc. In an effort to obtain high quality welds in shielded metal arc welding method, selection of ideal parameters should be performed according to engineering facts

### 2.2.1 Material type

Welding application will be realized for three different materials; namely plain carbon steel, alloy steel and stainless steel. Aluminum is not recommended for shielded metal arc welding method; therefore it is excluded in this technique.

### 2.2.2 Welding slot forms

Joining methods in welding design can be divided into four groups; such as butt, inner corner, outer corner and overlap. In welded parts, welding slot must be prepared to have better performance in joined area. The types of welding slots are determined in the related standards. international welding standard is valid in this subject and the types of welding slots are determined in detailed there.

#### Electrode diameter

The electrodes used in shielded metal arc welding are divided in two main groups as joining and filler welding ones according to the purpose of the welding. The coated electrodes are also classified by the tensile strength of the deposited weld metal, the welding position in which they may used, the preferred type of current and polarity, and the type of coating. The metal wire used in the process is usually from 1.5 to 6.5 mm in diameter and 20 and 45 cm in length

For selection of electrode; material type, welding position, welding current, welding slot form and work piece thickness above all are taken into consideration. The electrode diameter changes according to the material thickness and welding slot form. The most used electrodes in shielded metal arc welding applications are 2.50, 3.25 and 4.00 mm core diameter ones .The values of electrode core diameters are determined in Table 1 depending on work piece thickness.

#### A. Welding current

During the welding, that is, while arc occurs in welding period, current against working voltage is called as welding current. Welding machine is plugged into the alternative current and poles are determined. The cable tips connecting to electrode pliers and ground one are prepared, then electrode is attached to the pliers and arc occurs when electrode touches to work piece and consequently a permanent current circle continues. Welding current is set by welders prior to welding application. During the welding application, the value of welding current is not changed. However, arc is cut or current can be increased depending on welding application

#### B. Welding speed

The movement of arc welding along work piece or the length of weld seam made in unit time is known as welding speed. When the speed is slow during the welding process, stock weld metal

Page 20 of 47	Ministry of Labor and Skills Author/Copyright	<b>Performing Metal Arc Welding</b>	Version -1 September , 2022
---------------	--	-------------------------------------	--------------------------------

increases in the unit length and eventually it causes to enlarge the welding pool. With growing of weld metal and increasing of heat input, the molten metal flows into the front of arc within the welding slot and it affects the regular arc formation. The increment of speed causes to reduction of welding heat given to unit length and consequently the molten quantity of main metal decreases, this negatively affects the wetting of weld seam. The determined welding speeds are given in Table 2.1 according to the thickness of work piece (s), welding current (I) and diameter of electrode (d)

Table 2 1 Welding speeds according to work piece thickness (s), weld current (I) and electrode diameter

Work piece thickness (S)	Welding speed ( $V_L$ ), mm/s	Welding current (I)
$S \leq 3$	4.50	$d \times 40$ ampere
$S > 3 \leq 8$	4.00	$d \times 40$ ampere
$S > 8$	3.50	$d \times 40$ ampere

### C. Arc length

The importance of distance between electrode and work piece is vital for arc occurrence. The mentioning of arc length in various welding applications is required to understand the difference between arc lengths. If arc length is equal to electrode diameter, this is called as normal arc length. Long arc is obtained whenever arc length is greater than electrode diameter. The distances less than the electrode diameter are called as short arc length.

### D. Electrode advance angle

The molten metal can be transferred by arc along the welding process and the welder should orientate the arc to form melting on joining surfaces. The angle between electrode and advance direction is generally 45 to 70°, however this value can also be changed between 45to 90°. The main principle here is the angle should prevent the flowing of slag in front of arc excluding vertical welding from top to down.

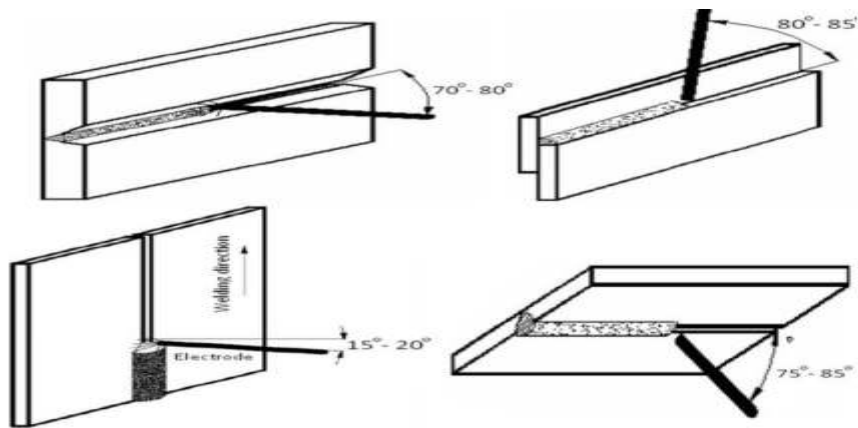

figure 2.1 The schematic view of advance angles depending on welding position

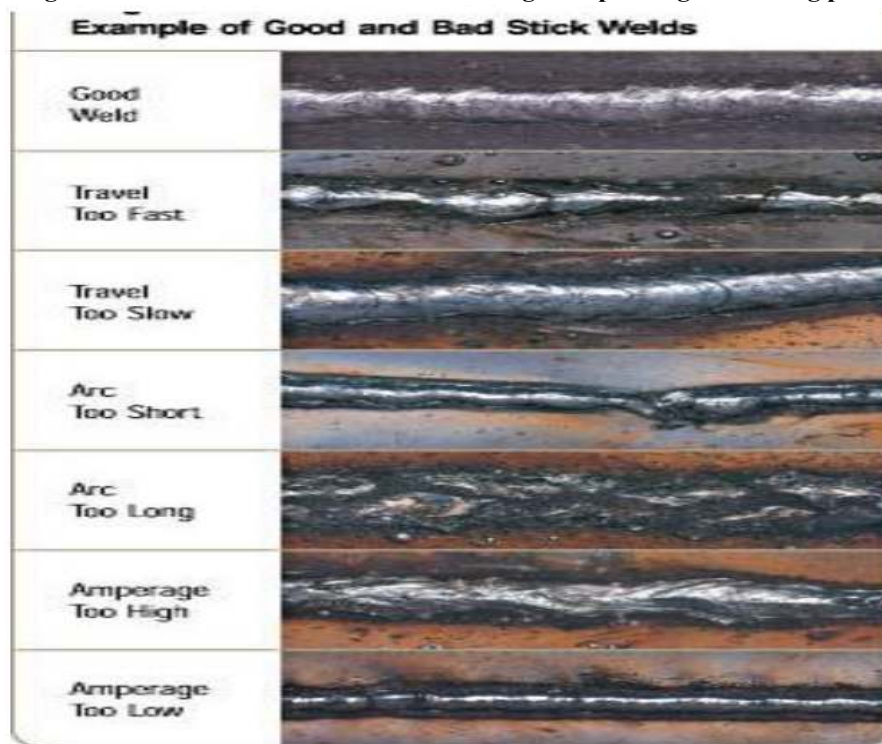

figure 2.2 Effects of the major weld parameters: speed, current and arc length

### 2.3 Preparing materials

Preparation the edges or surfaces of parts selected and to be joined by welding shall be prepared by shear, hack saw, power cutter or plasma arc cutting. Where hand cutting is involved the edge will be ground to a smooth surface. All surfaces and edges shall be free from fins, tears, cracks or any other defects which would adversely affect the quality of the weld. Before welding, the work pieces must be thoroughly cleaned of rust, scale and other foreign material. The piece for metal generally welded without beveling the edges, however, thick work pieces should be

beveled or vee'd out to ensure adequate penetration and fusion of all parts of the weld. But, in either case, the parts to be welded must be separated slightly to allow better penetration of the weld.

All moisture, grease or other foreign material that would prevent proper welding or produce objectionable fumes, shall be removed. Contact with lead, zinc, or lead or zinc compound shall be avoided due to the potential for hot cracking. All surfaces to be welded shall be wire brushed prior to welding. In multi-pass welds the weld bead shall be wire brushed between passes.

The brushes shall be of stainless steel and be kept exclusively for use on stainless steel and be kept clean and free of contaminants. All other equipment such as grinding discs shall be kept exclusively for use on stainless steels

### **2.3.1 Setting the work piece**

Once the selected work piece is prepared and cleaned, the next step is to tap the pieces to be joined after slightly striking electric arc on the way to checking whether the right amperage is set. Moreover, the tapped pieces should be positioned and clamped to a system of fixture. Generally the following should be considered while setting the work piece.

- Set the job in a flat position on the welding table
- Ensure there is good electrical contact between the job and the welding table.

### **2.3.2 Striking and maintaining an Arc**

Material: stick welding electrodes come in cast iron, high carbon steel, mild steel, iron-free (nonferrous), and special alloys.) Strength: referred to as tensile strength. Each weld needs to be stronger than the metal being welded. This means that the materials in the electrode need to be stronger as well.

Page 23 of 47	Ministry of Labor and Skills Author/Copyright	<b>Performing Metal Arc Welding</b>	Version -1 September , 2022
---------------	--	-------------------------------------	--------------------------------



**figure 2 3 Strike Welding**

It is an essential basic skill to learn in arc welding

**A. Scratching method:**

- Hold the electrode about 25 mm above the job piece at one end perpendicular to surface
- Bring the welding screen in front of your eyes.
- Ensure safety apparatus is worn
- Strike the arc by dragging the electrode quickly and softly across the welding job, using wrist movement only.
- Withdraw the electrode approximately 6 mm from the surface for a few seconds
- And then lower it to (approximately) 4mm distance.
- If the arc has been properly struck, a burst of light with a steady sharp crackling sound will be produced.

**Tapping method:**

- Strike the arc by moving the electrode down to touch the job surface lightly.
- Move the electrode slowly up approximately 6mm for a few seconds and then lower it to approximately 4 mm from the surface.

Page 24 of 47	Ministry of Labor and Skills Author/Copyright	<b>Performing Metal Arc Welding</b>	Version -1 September , 2022
---------------	--	-------------------------------------	--------------------------------



- The tapping method is generally recommended as it does not produce pit marks on the job surface

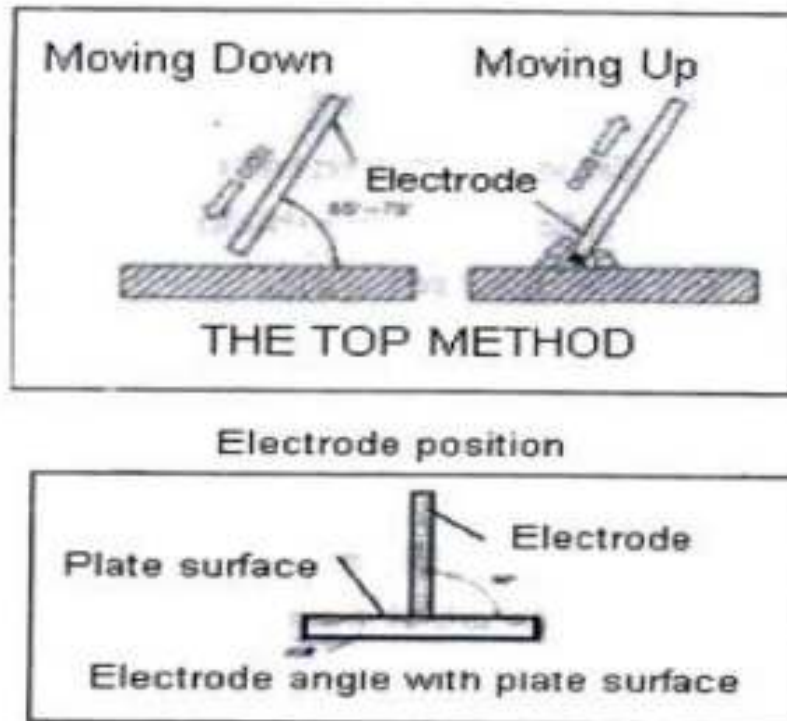

figure 2 4 scratching and tapping methods

## 2.4 Carrying out welding

### 2.4.1 Procedures for arc welding

To weld materials by manual arc welding, the following common procedures should be followed. Safety and other issues should be considered as described in the previous information sheets of this learning guide.

- Set the arc welding plant by one cable connection to electrode with electrode holder another connection for work piece with earthing clamp.
- Set the current range & electrode according to plate thickness.
  - Ex: 6mm plate i) Current range 120Amps
  - ii) Electrode size 3.2mm Dia
- Set the work piece for tack weld by fixing with C Clamp using suitable tack welding fixture.

Page 25 of 47	Ministry of Labor and Skills Author/Copyright	Performing Metal Arc Welding	Version -1 September , 2022
---------------	--	------------------------------	--------------------------------

- Tack the pieces at both ends by scratching or tapping method.
- Place the tack weld unit to full bead welding fixture as provided in working table.
- Deposits full bead weld with correct i) Arc lengths 3 to 5mm ii) Electrode angle 70° to 80° iii) Travel speed 150mm/min iv) uniform Movement v) Direction towards your end , usually from left to right for right handed welders.
- Reverse the joint to perform full bead on other end.
- Chip off all slag, remove spatters with using white spectacles
- Clean the bead by wire brush with using white spectacles
- Inspect the weld bead

This process employs coatings or fluxes to prevent the weld pool from the surrounding atmosphere.

- |                                   |                                  |
|-----------------------------------|----------------------------------|
| 1. Switch box.                    | 10. Hand shield                  |
| 2. Secondary terminals            | 11. Channel for cable protection |
| 3. .Welding machine.              | 12. Welding cable. \             |
| 4. Current reading scale.         | 13. Chipping hammer.             |
| 5. Current regulating hand wheel. | 14. Wire brush.                  |
| 6. 6Leather apron.                | 15. Earth clamp.                 |
| 7. Asbestos hand gloves.          | 16. Welding table (metallic).    |
| 8. Protective glasses strap       | 17. 17) Job.                     |
| 9. Electrode holder.              |                                  |

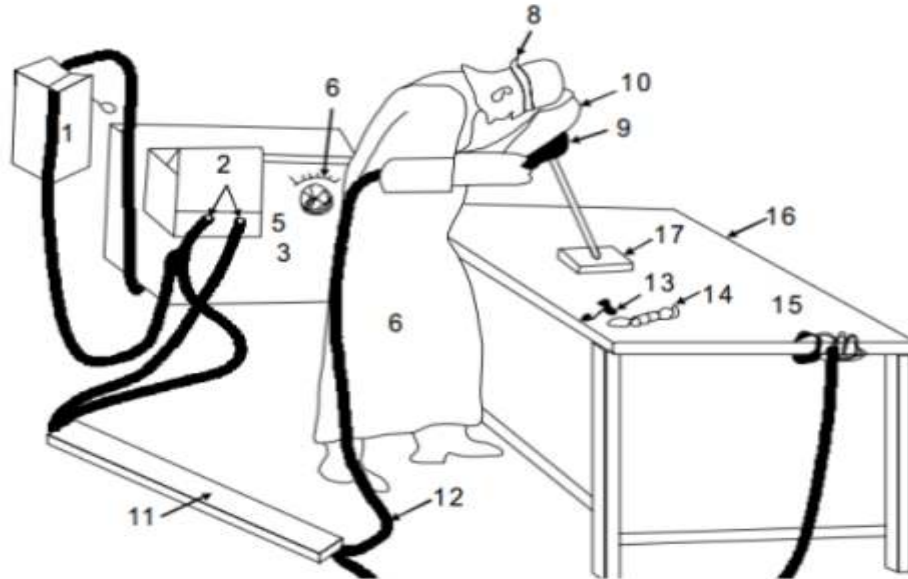

figure 2 5 .The basic elements of arc welding equipment

## 2.4.2 Welding joints

Most welding projects use at least one of the five welding joint types shown below. Understanding each welding joint type is an important part of becoming an experienced, successful welder

### Butt joint

- Joins two members that meet at their edges on the same plane
- Used in applications where a smooth weld face is required
- Fillet or groove welded; groove welding requires added expertise and expense
- Improper design/welding risks distortion and residual stresses

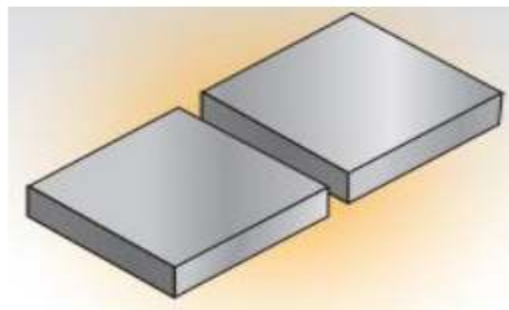

figure 2 6 butt joint

### 1. T-joint

Page 27 of 47	Ministry of Labor and Skills Author/Copyright	Performing Metal Arc Welding	Version -1 September , 2022
---------------	--	------------------------------	--------------------------------

- Joins two members that meet at a T-shaped angle
- Good mechanical properties, especially when welded from both sides
- Easily welded with little or no joint preparation
- Usually fillet welded, although J-grooves are possible

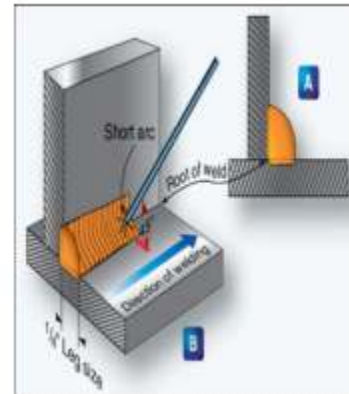
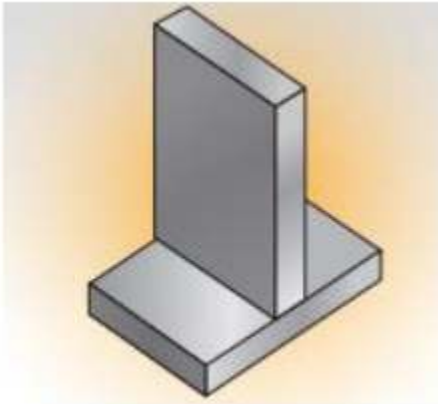

figure 2 7 T-joint

## 2. Lap Joint

- Joins two members having overlapping surfaces
- Good mechanical properties, especially when welded from both sides
- Usually fillet welded
- Thicker material requires more overlap

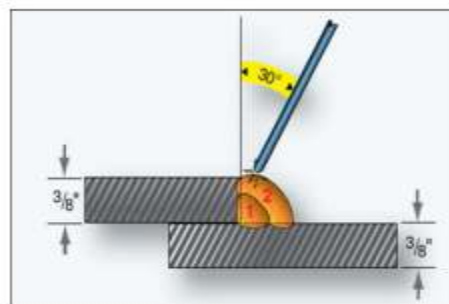
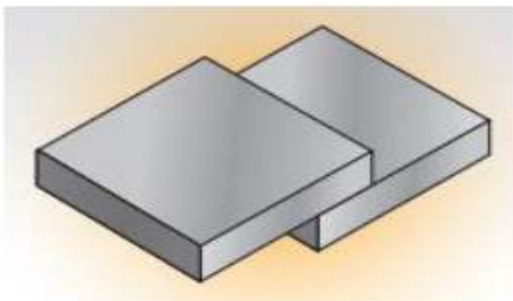
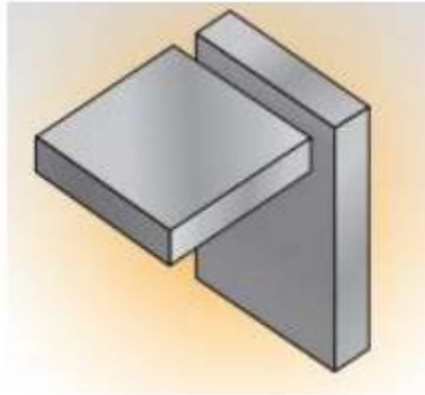

figure 2 8 Lap joint

## 3. Corner Joint

Page 28 of 47	Ministry of Labor and Skills Author/Copyright	Performing Metal Arc Welding	Version -1 September , 2022
---------------	--	------------------------------	--------------------------------

- Joins two members that meet at an angle
- Two main types: open corner and closed corner
- Easily welded with little or no joint preparation
- Increase travel speed on light-gauge material to avoid burn-through



**figure 2 9 Corner joint**

#### **4. Edge Joint**

- Joins two parallel, or nearly parallel, members
- Not recommended if either member will be subject to impact or high stresses
- Square groove is most common, but other groove configurations are possible
- Very deep penetration is impossible

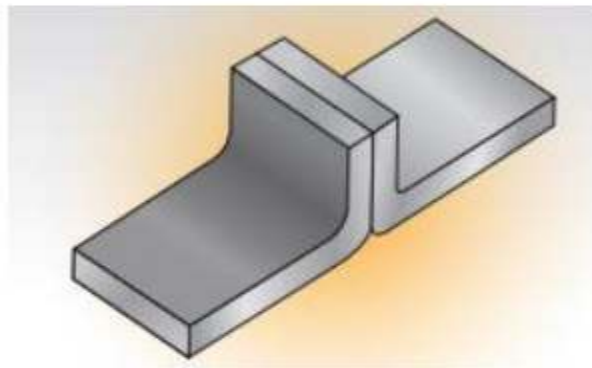

**figure 2 10 Edge joint**

#### **2.2.4 Welding positions**

Page 29 of 47	Ministry of Labor and Skills Author/Copyright	Performing Metal Arc Welding	version -1 September , 2022
---------------	--	------------------------------	--------------------------------

The welding positions are classified on the basis of the plane on which weld metal is deposited. The positions are flat, horizontal, vertical and overhead.

### 1. Flat welding

In flat welding, plates to be welded are placed on the horizontal plane and weld bead is also deposited horizontally (Fig. below). This is one of most commonly used and convenient welding position. Selection of welding parameters for flat welding is not very crucial for placing the weld metal at desired location in flat welding

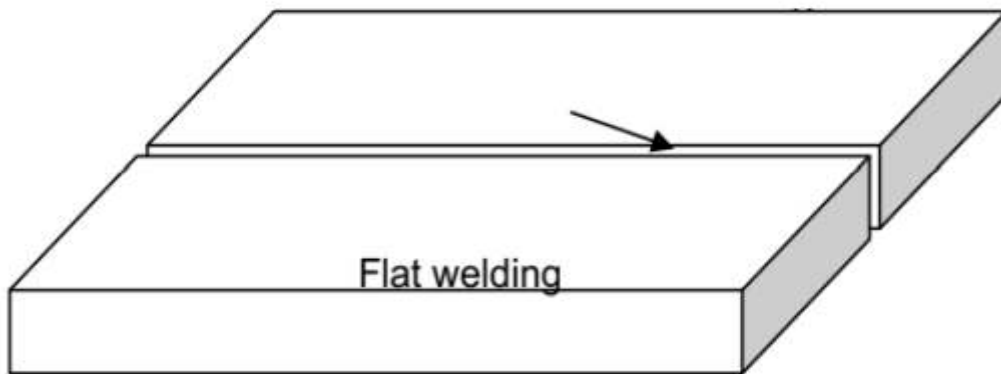

**figure 2 11** Scheme of placement of components to be welded for flat welding

There are four types of welds commonly used in flat position welding: bead, groove, fillet, and lap joint. Each type is discussed separately in the following paragraphs.

#### A. Head Weld

The bead weld utilizes the same technique that is used when depositing a bead on a flat metal surface. [Figure 2.12 ] The only difference is that the deposited bead is at the butt joint of two steel plates, fusing them together. Square butt joints may be welded in one or multiple passes. If the thickness of the metal is such that complete fusion cannot be obtained by welding from one side, the joint must be welded from both sides. Most joints should first be tack-welded to ensure alignment and reduce warping.

Page 30 of 47	Ministry of Labor and Skills Author/Copyright	<b>Performing Metal Arc Welding</b>	Version -1 September , 2022
---------------	--	-------------------------------------	--------------------------------

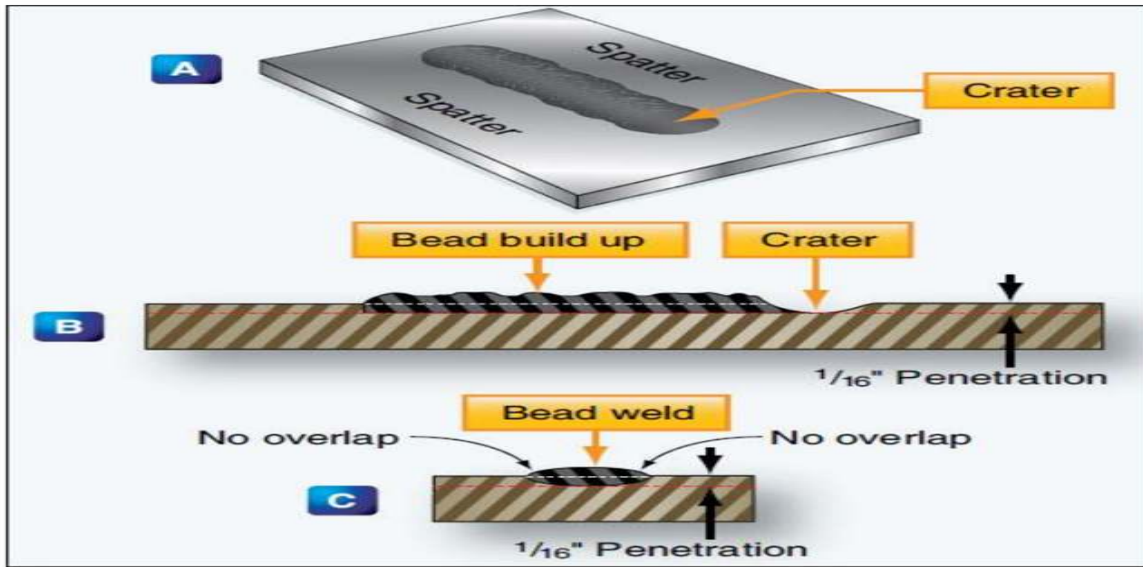

figure 2 12 Bead weld

### B. Groove Weld

Groove welding may be performed on a butt joint or an outside corner joint. Groove welds are made on butt joints where the metal to be welded is ¼-inch or more in thickness. The butt joint can be prepared using either a single or double groove depending on the thickness of the plate.

Any groove weld made in more than one pass must have the slag, spatter, and oxide carefully removed from all previous weld deposits before welding over them. Some of the common types of groove welds performed on butt joints in the flat position are shown in Figure 5.9.

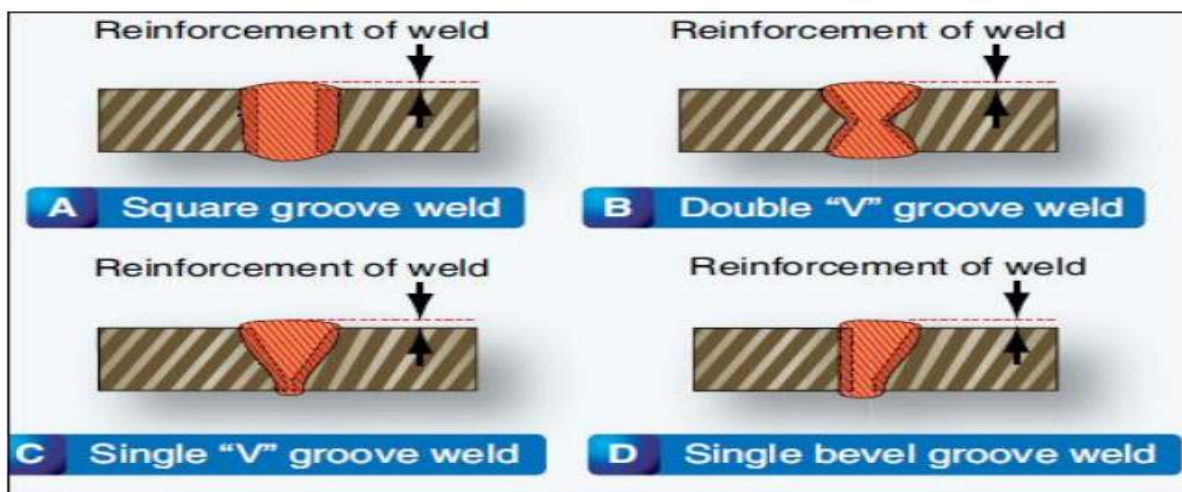

figure 2 13 Groove weld

### C. Fillet Weld

Fillet welds are used to make tee and lap joints. The electrode should be held at an angle of  $45^\circ$  to the plate surface. The electrode should be tilted at an angle of about  $15^\circ$  in the direction of welding. Thin plates should be welded with little or no weaving motion of the electrode and the weld is made in one pass. Fillet welding of thicker plates may require two or more passes using a semicircular weaving motion of the electrode.

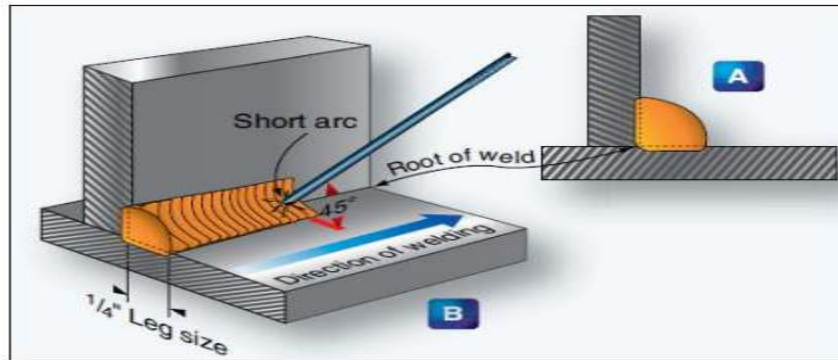

figure 2 14 Fillet weld

### D. Lap Joint Weld

The procedure for making fillet weld in a lap joint is similar to that used in the tee joint. The electrode is held at about a  $30^\circ$  angle to the vertical and tilted to an angle of about  $15^\circ$  in the direction of welding when joining plates of the same thickness

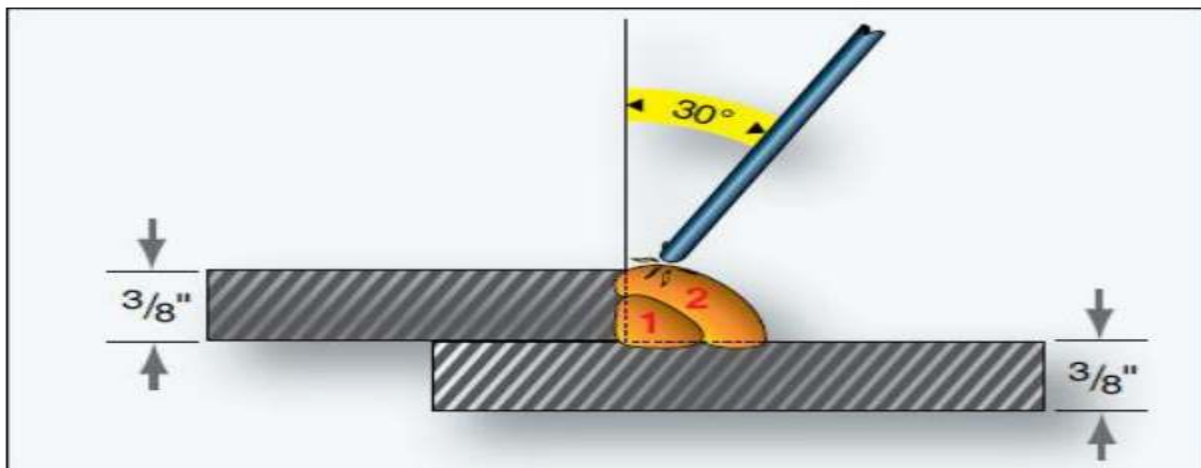

figure 2 15 Lap joint weld

Page 32 of 47	Ministry of Labor and Skills Author/Copyright	Performing Metal Arc Welding	Version -1 September , 2022
---------------	--	------------------------------	--------------------------------



## 2. Horizontal welding

horizontally (Figure 2.16 ). This technique is comparatively more difficult than flat welding. Welding parameters for horizontal welding should be selected carefully for easy manipulation/placement of weld metal at the desired location. In horizontal welding, plates to be welded are placed in vertical plane while weld bead is deposited

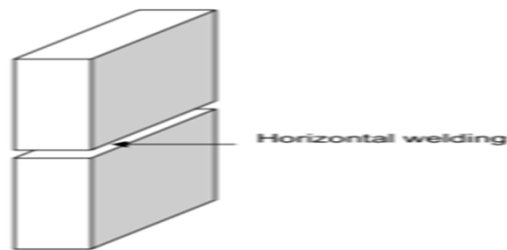

figure 2 16 Scheme of placement of components to be welded for horizontal welding

## 3. Vertical welding

In vertical welding, plates to be welded are placed on the vertical plane and weld bead is also deposited vertically (Figure 2.17.). It imposes difficulty in placing the molten weld metal from electrode in proper place along the weld line due to tendency of the melt to fall down under the influence of gravitational force.

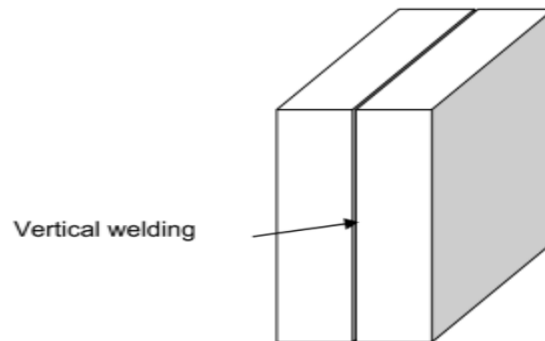
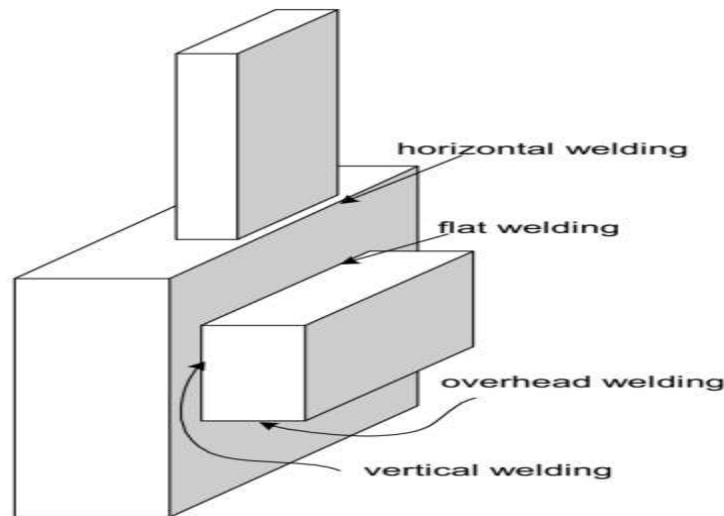

figure 2 17 : Scheme of placement of components to be welded for vertical welding

## 4. Overhead welding

n overhead welding, weld metal is deposited in such a way that face of the weld is largely downward and there is high tendency of falling down of weld metal during welding (Figure 2.18.). Molten weld metal is moved from the electrode (lower side) to base metal (upper side) with great care and difficulty hence,

Page 33 of 47	Ministry of Labor and Skills Author/Copyright	<b>Performing Metal Arc Welding</b>	Version -1 September , 2022
---------------	--	-------------------------------------	--------------------------------



**figure 2 18 Scheme of placement of components to be welded for different types of welding**

After preparing and setting the materials, the next step is welding and producing output as indicated in the following figure 5.19.

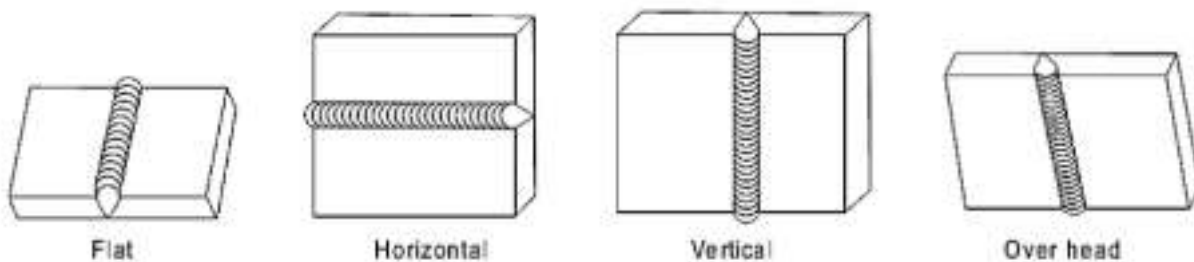

**figure 2 19 Different welding positions applied on butt joint.**

## 2.5 Cleaning welding seams

Cleaning is necessary before welding, during welding (interpass) and is usually essential after welding in order to ensure maximum corrosion resistance. Each welding run must be thoroughly cleaned to remove slag and spatter before proceeding with the next run. The cleaning method used (chipping, brushing, grinding) will depend on the welding process, bead shape, etc. but care should be taken to see that the weld area is not contaminated in the process. Any cleaning equipment should be suitable for stainless steel and kept for that purpose. During welding, a gas purge on the reverse side may be advantageous. After welding, weld spatter, flux, scale, arc strikes and the overall heat discoloration should be removed. This can involve grinding and polishing, blasting and brushing with a stainless steel wire brush, or use of a decaling solution or paste. The preferred procedure is usually dictated by end use. Grinding and dressing is to be

Page 34 of 47	Ministry of Labor and Skills Author/Copyright	<b>Performing Metal Arc Welding</b>	Version -1 September , 2022
---------------	--	-------------------------------------	--------------------------------

carried out with iron-free brushes, abrasives, etc. and should not be so heavy as to discolor and overheat the metal. Rubber and resin bonded wheels are satisfactory. Wheels should be dressed regularly to prevent them becoming loaded thereby producing objectionable scratches. In any blasting process steel shot shall not be used

Page 35 of 47	Ministry of Labor and Skills Author/Copyright	<b>Performing Metal Arc Welding</b>	Version -1
			September , 2022

## Self check 1

Directions: Short answer items Instruction: Briefly answer the following questions.

Instruction I say true or false

1. List the five types of welding joints.
2. What are the major types of welding positions? Explain with drawing
3. What is the difference between bead weld and groove weld?
4. With what type of welding joint is high penetration impossible?
5. While fillet welding the T-joint, how much should be the angle of the electrode from the plate face?

Page 36 of 47	Ministry of Labor and Skills Author/Copyright	<b>Performing Metal Arc Welding</b>	Version -1 September , 2022
---------------	--	-------------------------------------	--------------------------------

## Operation sheet 1    Setting up arc welding equipment

Basic procedures to set up a welding equipment

**Step-1:** Check the working of power source for the welding machine.

**Step-2:** Remember electricity is a good servant but a bad master.

**Step-3:** Call an electrician for solving any electrical problems.

**Step-4:** Connect the welding cables with the welding machines.

**Step-5:** Ensure that the cable connections are clean, dry, and are attached to the proper terminals of the machine.

**Step-6:** Attach tightly the earth cable with the welding table at the proper place.

**Step-7:** Keep the electrode-holder at a safe place

**Step-8:** If the machine is on D.C. power, connect the cables in correct polarity. Polarity means changing of +ve and -ve to the electrode is called polarity..

Page 37 of 47	Ministry of Labor and Skills Author/Copyright	<b>Performing Metal Arc Welding</b>	Version -1 September , 2022
---------------	--	-------------------------------------	--------------------------------

## Operation sheet: 2

To practice straight beads on the given mild steel flat piece in down hand position by arc welding.

Procedures to practice straight beads on mild steel piece

**Step-1:** Copy the given working drawing in the work record.

**Step-2:** Cut the work piece as per the drawing.

**Step-3:** File the work piece to the dimensional accuracy.

**Step-4:** Kept the work piece on the welding table in the down hand position.

**Step-5:** Set the ampere of the machine and use protective cloth , select suitable electrode and proper shield.

**Step-6:** Remove the slag and spatters using the chipping hammer and wire brush

**Step-7:** After completion of weld , the weld bead should be inspected.

Page 38 of 47	Ministry of Labor and Skills Author/Copyright	<b>Performing Metal Arc Welding</b>	Version -1
			September , 2022

## LAP Test Practical Demonstration

Name: \_\_\_\_\_ Date: \_\_\_\_\_ Time started:  
\_\_\_\_\_ Time finished: \_\_\_\_\_

**Instructions:** Given necessary templates, tools and materials you are required to perform the following tasks within 5-7 hours

Task 1: set up the arc welding equipment

Task 2: produce a straight bead on the mild steel as described on the working drawing 1

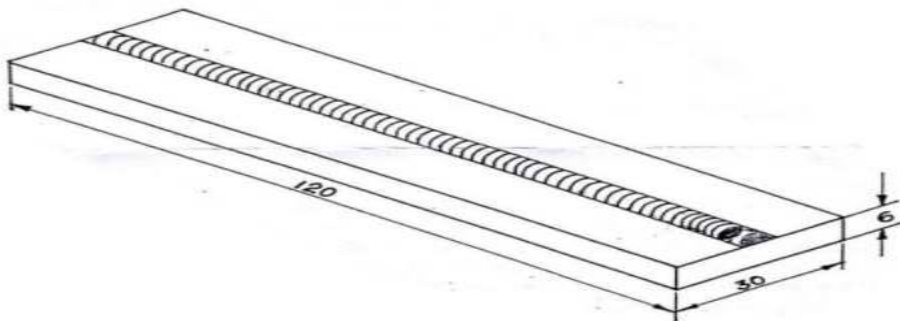

Working drawing 1

Task 3 : Make a T-joint using mild steel pieces dimension as indicated on working drawing 2

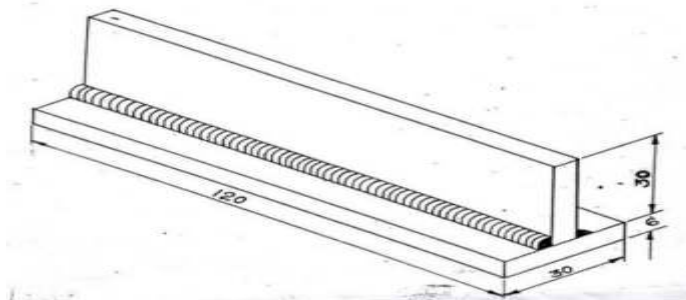

Working drawing 2

## Unit Three : Assure Quality and Clean Up

This unit to provide you the necessary information regarding the following content coverage and topics:

- Inspecting welding seams
- Measuring joins
- Cleaning and maintaining welding equipment and work area.

This guide will also assist you to attain the learning outcomes stated in the cover page. Specifically, upon completion of this learning guide, you will be able to:

- Inspecting welding seams
- Measuring joins
- Cleaning and maintaining welding equipment and work area.

### 3.1 Inspecting welding seams

Slag or flux remaining after a pass, shall be removed before applying the next covering pass. After the final pass all slag and weld spatter shall be removed. Arc strikes shall be removed by grinding or other suitable means. Cracks or blemishes caused by arc strike shall be ground to a smooth contour and examined visually to assure complete removal.

#### 3.1.1 Welding Defects

The lack of training to the operator or careless application of welding technologies may cause discontinuities in welding. In joints obtained by fusion welding, the defects such as porosity, slag inclusion, solidification cracks etc., are observed and these defects deteriorates the weld quality and joint properties.

Common weld defects found in welded joints

These defects may result in sudden failures which are unexpected as they give rise to stress intensities. The common weld defects include

- |                   |                     |
|-------------------|---------------------|
| 1. Porosity       | 5. Undercut         |
| 2. Lack of fusion | 6. Lamellar Tearing |
| 3. Inclusions     |                     |
| 4. Cracking       |                     |



## 1. Porosity

Occurs, when the solidifying weld metal has gases trapped in it. The presence of porosity in most of the welded joints is due to dirt on the surface of the metal to be welded or damp consumables. It is found in the shape of sphere or as elongated pockets. The region of distribution of the porosity is random and sometimes it is more concentrated in a certain region. By storing all the consumables in dry conditions and degreasing and cleaning the surface before welding, porosity can be avoided.

## 2 Lack of Fusion

Due to too little input or too slow traverse of the welding torch, lack of fusion arises. By increasing the temperature, by properly cleaning the weld surface before welding and by selecting the appropriate joint design and electrodes, a better weld can be obtained. On extending the fusion zone to the thickness of the joints fully, a good quality joint can be obtained.

## 3 Inclusions

Due to the trapping of the oxides, fluxes and electrode coating materials in the weld zone the inclusions are occurred. Inclusions occur while joining thick plates in several runs using flux cored or flux coated rods and the slag covering a run is not totally removed after every run and before the next run starts. By maintaining a clean surface before the run is started, providing sufficient space for the molten weld metal between the pieces to be joined, the inclusions can be prevented.

## 4 Cracking

Due to thermal shrinkage, strain at the time of phase change, cracks may occur in various directions and in various locations in the weld area. Due to poor design and inappropriate procedure of joining high residual stresses, cracking is observed. A stage-wise pre-heating process and stage-wise slow cooling will prevent such type of cracks. This can greatly increase the cost of welded joints. Cracks are classified as hot cracking and hydrogen induced cracking. A schematic diagram of centerline crack is shown below fig. 3.1

The cracking can be minimized by preferring fillers with low carbon and low impurity levels. The solidification cracking can be avoided by reducing the gaps and cleaning the surface before welding.

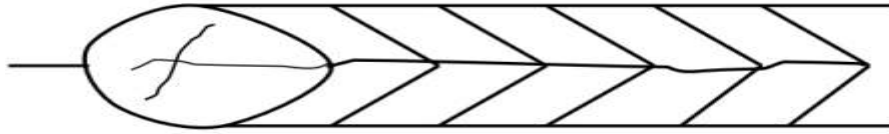

figure 3 1 Schematic diagram of centerline crack

## 5 Undercutting

The undercut is caused due to incorrect settings or using improper procedure. Undercutting can be detected by a naked eye and the excess

## 6 Lamellar Tearing

Due to nonmetallic inclusions, the lamellar tearing occurs through the thickness direction. This is more evidently found in rolled plates. As the fusion boundary is parallel to the rolling plane in T and corner joints, the lamellar tearing occur. By redesigning the joint and by buttering the weld area with ductile material, the lamellar tearing can be minimized.

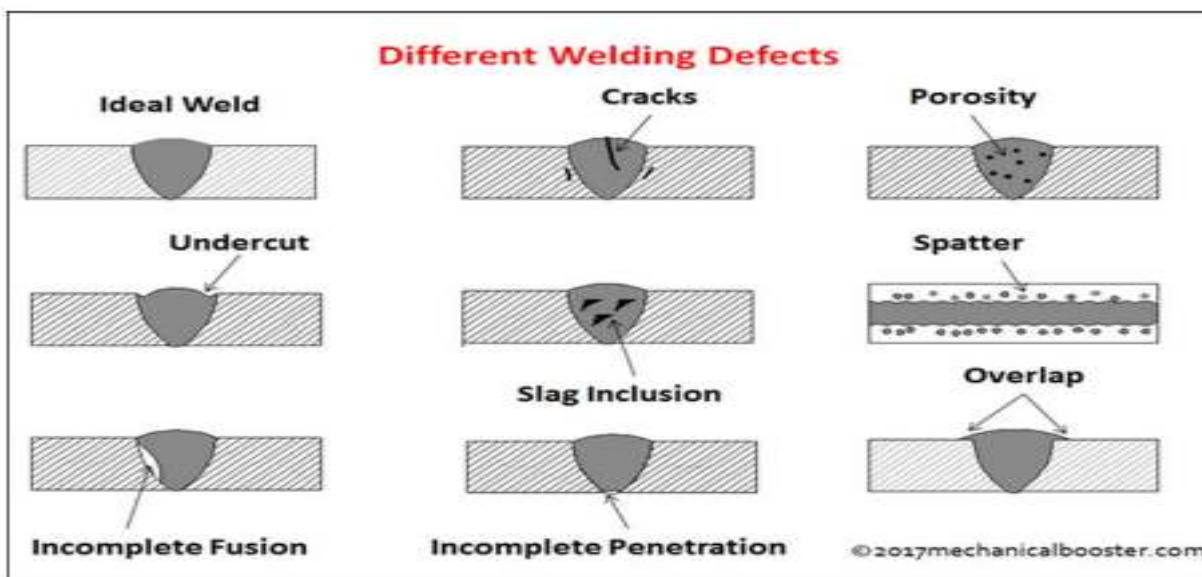

figure 3 2 Different welding defects

Page 42 of 47	Ministry of Labor and Skills Author/Copyright	Performing Metal Arc Welding	Version -1 September , 2022
---------------	--	------------------------------	--------------------------------

## 3.2 Measuring joints

### 3.2.1 Inspection Tools and Measurements

Measurement and inspection of welded joint is an important step in quality control and reliability of welded constructions. External inspection allows you to detect such external defects such as undercuts, uncertified craters facing surface cracks, lack of fusion, flows, etc. Meters of welded joints and welding templates (templates welder) allow us to determine the size of joints, joint width and high, angle of bevel, depth and width of preparation, included angle, root gap, dept of root face, convexity, smoothness of transition weld to the base metal, leg length, etc.

### 3.2.2 Measuring joints and other defects

#### A. Fillet welds

The leg length of the largest right isosceles triangle that can be inscribed within the fillet weld cross section is the size of the fillet weld. There are two types of fillet welds: concave and convex. The fillet weld type is determined by the shape of the fillet weld. Fillet weld gauges such as the ones in Figure below are for specific size fillet welds and are two-sided in order to measure both concave and convex fillet welds. Be sure to use the proper side of the gauge for the fillet weld type being measured.

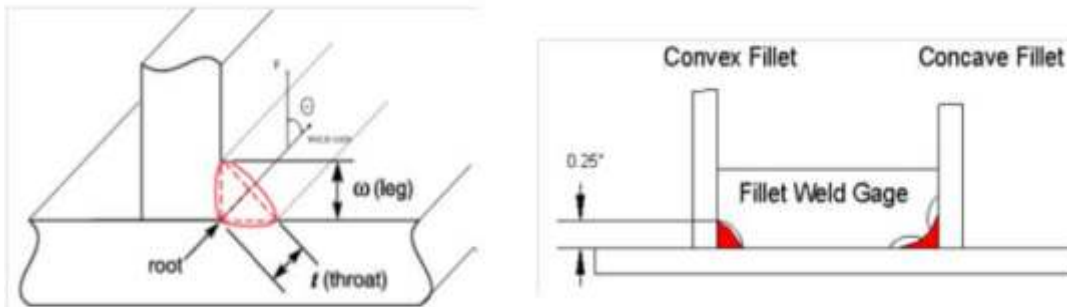

figure 3 3 weld fillet gauges

#### B. Undercut

Undercut is measured from the surface of the base metal to the deepest point of the undercut. Undercut can be quickly identified by running a flashlight along the edge of weld parallel to the surface of the base metal.

Page 43 of 47	Ministry of Labor and Skills Author/Copyright	<b>Performing Metal Arc Welding</b>	Version -1 September , 2022
---------------	--	-------------------------------------	--------------------------------



### 3.3 Cleaning and maintaining work area and welding equipment

#### 3.3.1 Cleaning welding equipment and work area

Tool housekeeping is very important, whether in the tool room, on the rack, in the yard, or on the bench all ways after completing operations. Tools require suitable fixtures with marked locations to provide an orderly arrangement. Returning tools promptly after use reduces the chance of it being misplaced or lost. Workers should regularly inspect, clean and repair all tools and take any damaged or worn tools out of service.

- Ensure sufficient time for materials to cool before handling.
- Switch off machine and fume extraction (if relevant).
- Hang up electrode holder and welding cables.
- Practice good housekeeping and ensure the area is clean and tidy.

#### 3.3.2 Maintenance of equipment

You must ensure that any equipment used in welding is adequately maintained. Electrical equipment such as power sources, generators and welding machines and devices like ventilation systems and equipment must be properly installed, maintained, repaired and tested. Equipment used with compressed gases, including regulators, must be properly maintained to prevent hazards such as gas leaks. Persons with management or control of workplaces must ensure that gas cylinders are regularly inspected by a competent person. They should frequently check whether cylinders and regulators are visibly damaged or corroded, and whether they are within test date. Gas pipes, hoses and tubing can easily become damaged over time so these should also be inspected regularly. PPE must be maintained to be in good working order and kept clean and hygienic. Some types of personal protective equipment have a limited life span and need to be replaced periodically, while other types of personal protective equipment may become damaged or ineffective if stored incorrectly. For example, some respirators and filters can absorb toxins and contaminants in the air when stored between uses. PPE should be stored in a clean environment to avoid contamination or damage or according to instructions provided by the manufacturer

Page 45 of 47	Ministry of Labor and Skills Author/Copyright	<b>Performing Metal Arc Welding</b>	Version -1 September , 2022
---------------	--	-------------------------------------	--------------------------------

### Self check 1

Name..... ID..... Date.....

**Directions: Short answer items Instruction: Briefly answer the following questions Test I say true or false**

1. What are the proper procedures that should be followed before cleaning and maintaining your workshop?
2. What is preventive maintenance?
3. What are the benefits of keeping clean workshop and machinery?
4. How can machine shop layout contribute to productivity of welding shop?
5. Who is responsible to maintain the workshop and machinery clean?

