

Mechanics Level – I

Based on March 2022 Curriculum Version 1

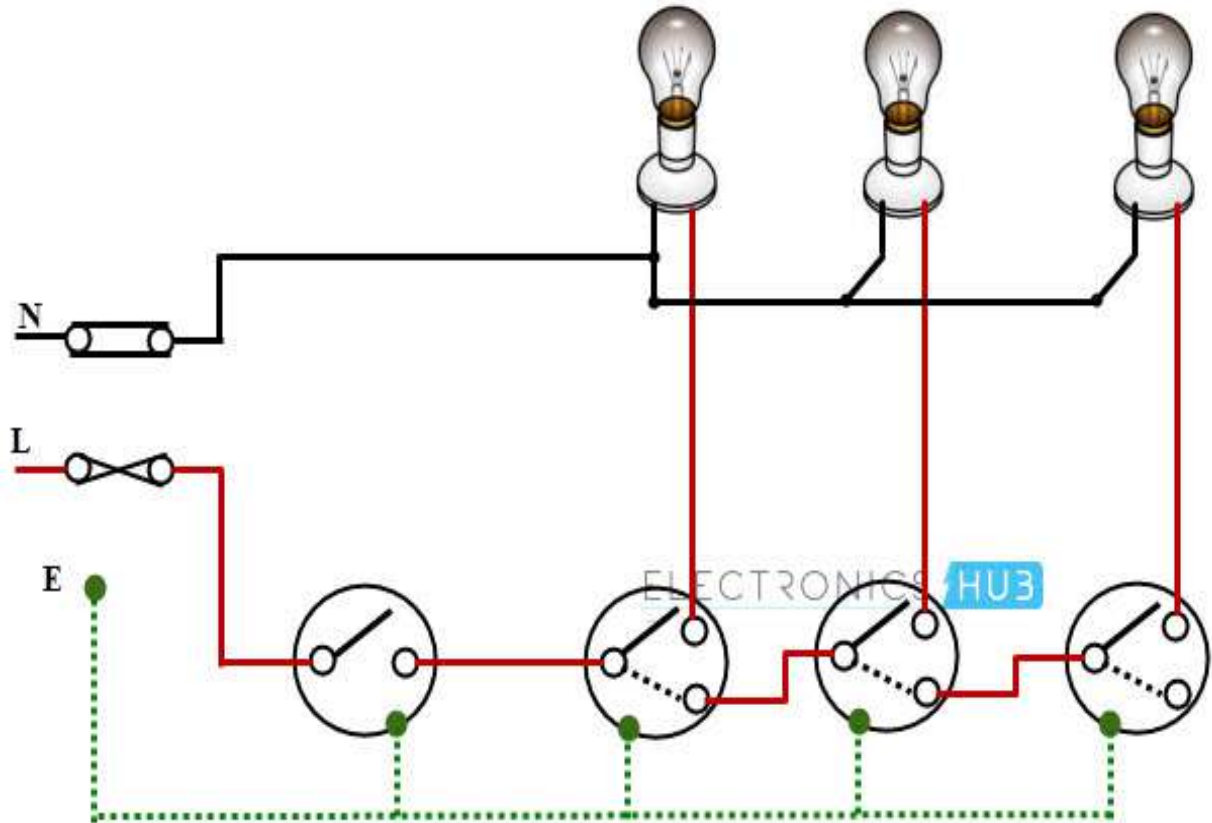

Module Title: - Apply Basic Electrical Practices

Module code: IND MCS1 M04 0322

Nominal duration: 40Hour

Prepared by: Ministry of Labor and Skill

**August, 2022
Addis Ababa, Ethiopia**

Table of Content

Acknowledgment -----	
---	5
Introduction to the Module	7
Unit one: work preparation for Basic Electrical Practices	8
1.introduction	9
1.1 Work requirements for Basic Electrical Practices	9
1.1.1Installing electrical Wiring systems	10
1.1.2Electrical Energy Distribution Systems	11
1.1.3 Distribution Board System	11
1.1.4System of Wiring	13
1.1.5 General Rules for Wiring	14
1.1.6Selection of Wiring Accessories	16
1.1.7Electric Circuit.....	17
1.2 occupational health and safety standards.....	17
1.2.1Safety	20
1.2.2 Undertaking all work safely and to workplace procedures	20
1.2.3 Workplace Electrical Safety Tips	21
Figure 1.2.3 Wall sticker socket.....	21
1.3 Required materials and equipment for the tasks	22
1.3.1 Wire materials.....	22
1.3.2 tools and materials used for connecting/terminating wires.....	23
1.3.3 Wiring enclosures and equipment	31
1.3.4 Electrical Cables	32
1.3.5 Insulating Materials.....	33
1.4 Interpreting relevant plans, drawings and texts	36
1.4.1 Layout and Installation Drawing	36
1.4.2 Marking of equipment.....	36
1.4.3 Interpreting electrical Diagrams and drawings	37
1.4.4 Detail Drawings and Assembly Drawings:.....	37
1.4.5 Location Drawings:.....	37
1.4.6 Block Diagrams:	37
1.4.7 Wiring Diagrams:.....	38
1.4.8Circuit Diagrams:.....	38
1.4.9 schematic Diagrams	39
1.5 Set-up work plan in detail.....	39
1.5.1General Wire-Stripping Instructions.....	39
1.5.2 Insulation Removal.....	40
1.5.3 Types of Splices	41
1.5.4 Splice Insulation	44
1.5.5Types of Conduits.....	46
1.5.6 Lighting circuits.....	48

1.5.7 Lighting layouts.....	52
1.5.8 Earthing	55
1.6 prevention potential hazards.....	56
1.6.1 Electrical Hazards.....	56
1.6.2 Safety Steps for Electrical Hazards	57
1.6.3 Dangers of Electrical Shocks.....	57
1.2.4 Safety Signs	59
1.7 Prepare work area	62
1.7.1 Consider Before Starting an Electrical Project	62
1.8 Resolve co-ordination requirements	62
1.8.1 Establish effective communication	62
1.8.2 Establish effective coordination	62
Self check-1	63
Operation sheet - 1	65
Lap Test- 1.....	66
Unit Two: Conduct Minor Handling and Maintenance	67
2.1 essential of isolations.....	67
2.1.2 Energy Isolation.....	67
2.1.3 Isolation:	68
2.1.4 Safe Isolation Practice.....	69
2.1.5 Safe Electrical Isolation and Lock Off.....	72
2.1.6 Safe isolation procedures & proper equipment save lives.....	73
Figure 2.1.6.1 basic kit in Isolation	73
2.1.7 Steps to Safe Isolation.....	73
2.2.1 Basic Maintenance of Electrical Tools and Equipment.....	75
2.2.2 Maintenance	75
2.3 minor adjustments.....	81
2.3.1 Adjustment of Electrical installation – Protective devices.....	81
2.3.2 adjustments of Switches, socket outlets and fixed outlets.....	81
2.4 Reporting fault.....	84
2.4.1 Causes of power system faults.....	84
2.4.2 Common power system faults	84
2.4.3 Notify or report work completion.....	84
2.4.4 Respond unplanned events or condition	85
2.4.5 Obtain approval from appropriate personnel before any implement	85
. self check- 2.....	85
Test-I.....	85
Test-II.....	85

Operation 2	86
Lap Test 2.....	87
Operation sheet- 3.....	87
Lap Test-3.....	88
Operation sheet- 4.....	88
Lap Test-4.....	89
Unit Three: Notify the completion of quality work	90
3.1 Complete work responsible personnel.....	90
3.2 final checks with supervisor	93
3.2.1 Continuity Test.....	93
3.2.2 Polarity Test.....	95
3.3 restored work area	98
3.3.1 clean, check, maintain and store Plant, tools and equipment	98
3.3.2 Electrical Emergencies	99
3.3.3 Electrical Rescue Techniques	99
3.4 Maintaining and Storing Tools & Equipment.....	99
3.4.2 Method of identifying non-functional tools and equipment	101
Figure 3.4.2	101
Figure 3.4.2	102
self-check -3	102
Test-I.....	102
Test-II.....	103
Test-III.....	103

Acknowledgment

Ministry of Labor and Skills wish to extend thanks and appreciation to the many representatives of TVT instructors and respective industry experts who donated their time and expertise to the development of this Teaching, Training and Learning Materials (TTLM).

Acronym

1. RCD - Residual Current Device
- 2 RCBO - Residual Current Circuit Breaker
3. PPE - Personal Protective Equipment
4. IEE - Institution of Electrical Engineers

Introduction to the Module

In mechanics field ; the Applying Basic Electrical Practices is provides a sound basic knowledge skills, and attitudes required to apply minor/basic handling and maintenance practices associated with a range of electrical equipment at the metal engineering workplace of electrical wiring cables, know that of current selection and wires that current carrying capacities measurement, quantity ,efficiency it helps to delivering the electrical energy efficiently also The voltage electrical system helps to know the electric circuit, and each component of the circuit quantity of work; to estimate the quantity of material required; to determine the cost of the work;

This module is designed to meet the industry requirement under the **mechanics** occupational standard, particularly for the unit of competency: **Apply Basic Electrical Practices**

This module covers the units:

- Prepare for work
- Conduct minor handling and maintenance
- Notify the completion of quality work

Learning Objective of the Module

- Identify basic electrical Work requirements
- Perform minor handling and maintenance
- notify Complete work

Module Instruction

For effective use this modules trainees are expected to follow the following module instruction:

1. Read the information written in each unit
2. Accomplish the Self-checks at the end of each unit
3. Perform Operation Sheets which were provided at the end of units
4. Do the “LAP test” giver at the end of each unit and
5. Read the identified reference book for Examples and exercise

Unit one: Work preparation for Basic Electrical Practices

This unit is developed to provide you the necessary information regarding the following content coverage and topics:

- work requirements for Basic Electrical Practices
- occupational health and safety standards
- Required materials and equipment For the tasks
- Interpreting relevant plans, drawings and texts
- Set-up work plan in detail
- prevention potential hazards
- Preparing work area
- Resolving co-ordination requirements

This unit will also assist you to attain the learning outcomes stated in the cover page. Specifically, upon completion of this learning guide, you will be able to:

- Identify work requirements
- Identify occupational health and safety standards
- Select materials and equipment required to perform the tasks
- Identify and interpreting relevant plans, drawings and texts
- Set-up work plan in detail
- Identify and prevention potential hazards
- Prepare work area
- Resolve co-ordination requirements

1. Introduction about Electricity

Electricity is everywhere in our lives. Electricity lights up our homes, cooks our food, powers our computers, television sets, and other electronic devices. Electricity (DC Current) from batteries starts our cars and makes our flashlights shine in the dark. But what is electricity? Where does it come from? How does it work? What are the hazards? Before we understand all that, we need to know a little bit about atoms and their structure.



Figure 1.1 The structure of atom

All matter is made up of atoms, and atoms are made up of smaller particles. The three main particles making up an atom are the proton, the neutron and the electron. Electrons spin around the center, or nucleus. The nucleus is made up of neutrons and protons. Electrons contain a negative charge, protons a positive charge. Neutrons are neutral -- they have neither a positive nor a negative charge. Each atom has a specific number of electrons, protons and neutrons. But no matter how many particles an atom has, the number of electrons usually needs to be the same as the number of protons. If the numbers are the same, the atom is called balanced, and it is very stable.

1.1 Work requirements for Basic Electrical Practices

IFS (infrastructure and facilities service) will oversee these general requirements which will apply to managing electrical equipment safely:

All electrical equipment maintenance and installation will only be undertaken by competent contractors and their workers;

- Each exposed part of electrical equipment is to be treated as if it is energized until it is isolated and it is proven not to be energized i.e. TEST before touch;
- Electrical switchboards and all isolators for de-energizing electrical circuits and other energy sources will be labeled;
- All enclosures housing electrical equipment such as substations and switchboards will be fitted with locks and signs to prevent access by unauthorized persons;
- Only competent and authorized personnel will be permitted to access electrical installations such as substations and switchboards;

- Wherever possible the space around electrical installations and circuits will have sufficient clearance for safe working conditions;
- Sufficient light will be installed in the vicinity of electrical installations and circuits to be able to see clearly all labels and markings;

IFS will have a plan for the maintenance of electrical equipment and installations which will be compliant with manufacturer's instructions.

- When someone wants to strengthen existing relationships and build new ones that will promote successful community development in the future.

1.1.1 Installing electrical Wiring systems

A wiring system is defined in BS 7671 as 'an assembly made up of cable or bus bar sand parts which secure, and if necessary enclose, the cable or bus bars'. A description of a wiring system includes the type of cable (or bus bar) and how it is supported and protected. It is conventional to recognize three types of circuit: mains, sub mains and final, with which experience tends to associate certain types of wiring system. A main circuit feeds a distribution board located at the center of a group of loads or it may feed a single large load. In extensive installations it may be appropriate to divide the circuit's further using sub mains which connect a main distribution board to smaller boards more convenient to load groups. In very large installations the main distribution board may feed one or more section boards which in turn feed further distribution boards.

Final or wiring circuits connect distribution boards to individual points of utilization.

For small installations, such as in most domestic and small commercial premises, it is usual for a distribution board to be located at the supply intake, when it takes the form of a consumer unit, with final circuits going directly to points of utilization. A network of cables connecting various electrical accessories for distribution of electrical energy from the supplier meter board to the various electrical energy consuming devices such as lamps, fans, radio, TV and other domestic appliances through controlling and safety devices is known as wiring system.

The supplier (i.e. EEPSCO) service cable feeding an installation terminates at services fuses (sometimes called service cutouts). Service cutouts including service meter (i.e. energy meter) remains the property of the supplier. The point at which the consumer wiring is connected into the cutout is known as point of commencement of supply or consumers terminals. From consumer terminals onwards the supply cables are under the control of consumers and so lay as per his choice. Figure (1.2) illustrates a typical house wiring.

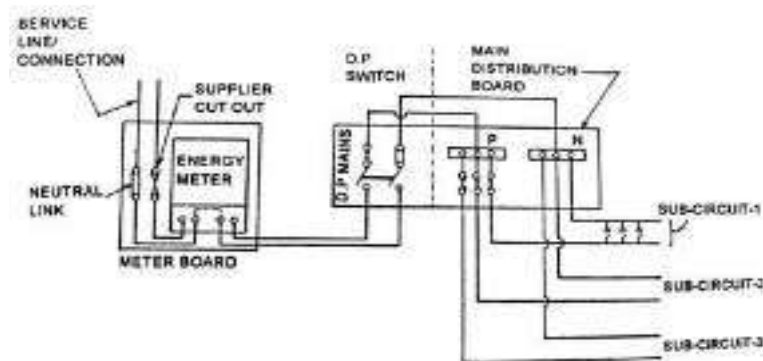

Figure 1.2 a Typical House Wiring

Table 1 Steps for wiring system and installations

Steps	Activities to be carried out
1	Conduit in slab and Junction boxes
2	Conduit in wall , distribution board and out let boxes
3	Pulling gay wire and wiring
4	Splicing, connections and insulating
5	Fixing fixtures (lamps, switches, circuit breakers, socket out lets, junction box covers)
5	Testing & Commissioning
6	Final completion submission of completion drawings Electrical Inspector approval.

1.1.2 Electrical Energy Distribution Systems

As per the recommendations of ISI the maximum number of points of lights, fans and socket outlets cannot be exceed beyond 10 and the maximum load that can be connected in such a circuit is 800 watt. Hence in case of more load or more points to be connected to the supply system, then it is to be done by having more than one circuit through (a) distribution board system and (b) the tree system (c) Joint box system and (d) loop in system.

1.1.3 Distribution Board System: It is the most commonly adopted system for distribution of electrical energy in buildings. The fuses of all circuits are grouped on a distribution board and are also known as fuse board [now days the DP (double-pole) main switch and fuses are grouped on a single board only]. The distribution board shown in has 3 sub-circuits or ways, each circuit is provided with a fuse. The lamps or fans connected to each circuit need not be in the same room or even on the same floor. For determination of electrical load of an installation, the following ratings of the appliance may be assumed unless specified:

- i. Incandescent lamp 60W
- ii. Fluorescent lamp 40W
- iii. Fans 80W
- iv. Socket outlets 100W
- v. Power socket Outlets1, 000 W etc.

A. **Tree System:** In tree system the sub circuits are taken from the main circuit or main line as shown in Figure 1.3 The wiring system resembles like a tree, hence it is known as tree system. Now a days this system is obsolete due to scattered fuses, more number of joints involved, and difficulty to find the fault since the joints will be beneath the roof or floor and the lamps in the last sub-circuit will have less voltage because of more voltage drop in leads etc.

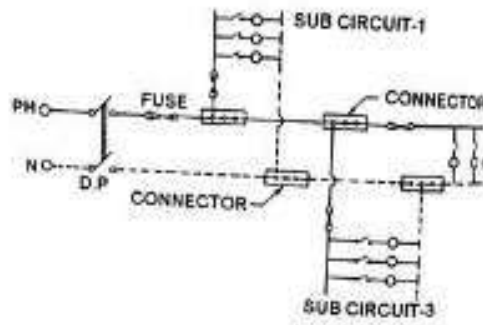

Figure 1.3 Tree System

B. Joint Box or Tee System: In this system the connections to the lamps are made through joints made in joint boxes by means of connectors. The disadvantage of this system is that more number of T-connections in the wiring.

Now days the use of this system is limited to temporary installation only as its cost is low and less cable is required.

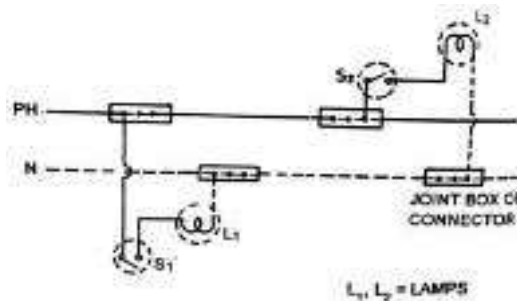

Figure 1.4 Joint Boxes or Tee System:

C. Loop in System: This system is universally adopted for connections of various lamps, fans and other appliances to the supply source. In this system the feed conductor looped in by bringing it direct to the terminal and then carrying it forward again to the next point to be feed as shown in Figure 1.4

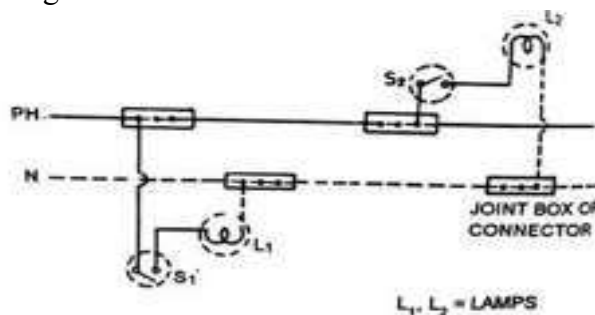

Figure. 1.5 Loop in System

- **Advantages of loop – In – system:**
 - Joint boxes or connectors are avoided.
 - No joint is made in the run cable.
 - Joints are not concealed beneath the floor or roof.
 - All the joints are at switches and lamps or fans which are accessible for inspection in case of faults simply by removing the fitments concerned.
- **Disadvantages of loop – in – system:**
 - Length of the cable required is more:

- Voltage drop and copper losses are more.
- Looping – in switches and lamps is usually difficult.

Another method of loop in is with the help of 2 plate ceiling roses as shown in Figure 1.6

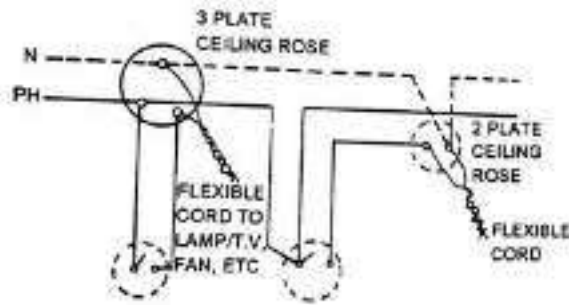

Figure 1.6 Looping in from Ceiling Rose

1.1.4 System of Wiring

The following are the different types of house wiring system:

1. Cleat wiring
2. Wooden casing capping
3. CTS or TRS wiring
4. Lead (or metal) Sheathed Wiring
5. Conduit Wiring
 - a) Surface or open type
 - b) Recessed or concealed type.

The following points to be considered before deciding any type of wiring:

- **Durability:** The wires selected must be durable and it must be able to withstand wear and tear due to weather.
- **Safety:** It is one of the foremost points to be considered. The system selected should be such that poor workman ship may not produce dangerous results.
- **Cost:** The system adopted must be economical to suit the purse of the individual concerned.
- **Appearance:** The appearance of wiring has an important bearing on the architectural beauty and, from aesthetic point of view; concealed conduit wiring is the proper choice.
- **Accessibility:** The repair and/or extension of the wiring should be feasible.

1.1.5 General Rules for Wiring

a. Specifying wiring regulations, EBCS-10 standards

The following general rules should be kept in mind while executing the electrical wiring work:

- The current rating of the cable / conductor should be slightly greater (at least 1.5 times) than the load current.
- Every live wire / line should be protected by a fuse of suitable rating as per load requirements.
- Every sub-circuit should be connected with the fuse distribution board.

- All metal coverings used for the protection of earth must be connected to earth.
- No switch or fuse is used in earth or neutral conductor.
- Every apparatus should be provided with a separate switch.
- No additional load should be connected to the existing installation until it has been satisfied that the installation can safely carry the additional load.
- All the switches and starters should be accessible to the operator.
- A caution notice (danger plate) should be fixed on very equipment.
- In any building light wiring and power wiring should be kept separately.
- In 3-phase, 4 – wire installation the load should be distributed almost equally on all the phases.
- In case of 3-phse, 4-wire system, at the main board, indication should be done in Red, Yellow and Blue. Neutral should be indicated in black.

a. Selection of Wiring Cable Type

The selection of the cable size has to take into consideration the following:-

- All wiring cables must be PVC or PVC/PVC insulated with copper conductors. Conductors with cross sectional areas of 16mm² or less must be of copper. Aluminum conductors are not permitted.
- Select the current carrying capacities of copper conductor;
- Cables for swimming pools must be water resistant PE (polyethylene) insulated;
- The selected cable must be capable of delivering the electrical energy efficiently;
- The cable size allows it to carry the current without heating the cable;
- The voltage drop must not exceed $\pm 2.5\%$ of the supply voltage.
- The cable insulation must be suitable for the surrounding conditions of the installation, such as the ability to withstand the surrounding temperatures and the ability to provide mechanical protection;
- Each conductor in the installation must be protected from over current by means of over current protection devices needed to prevent damage to the cable insulation.

Table 2 Use of Minimum Cross Sectional Area Rating of Wiring Conductors

The following are the minimum cross sectional areas of conductors based on their applications:-

Conductor Cross Sectional Area in mm ²	Material	Application
1.5 mm ²	Copper	Lighting/fan circuit
2.5 mm ²	Copper	13A socket outlet circuit
4.0 mm ² – 6.0 mm ²	Copper	General Power Circuit (example: water heater, cooker unit, motor/pump)
16.0 mm ² / 25.0 mm ²	Copper	Main Circuit

Table 3 Functions and Color Identification of Non Flexible Cables

The following table shows the functions and color identification of non flexible cables:

Page 14 of 102	Ministry of Labor and Skills Author/Copyright	Apply Basic Electrical Practices	Version -1 August 2022
----------------	--	----------------------------------	---------------------------

Function	Cable Colour
Phase of Single Phase Circuit	Red, Yellow or Blue
Red Phase of Three Phase Circuit	Red

Table 4 Functions and Color Identification of Flexible Cables

Yellow Phase of Three Phase Circuit	Yellow
Blue Phase of Three Phase Circuit	Blue
Neutral of Circuit	Black
Protection/Earthing Conductor	Green or Green-Yellow

Flexible Cables

- Flexible cables of cross sectional area less than 4.0 mm² are used in installations for electrical accessories such as ceiling roses, lamp
- Fixtures or attachments, socket plugs for mobile appliances, etc..
- Flexible cables shall not be used for permanent wiring.
- Flexible cables for the permanent use of electrical appliances should not exceed 3 meters in length.

Table 5 Conductor Insulation and Types of Wiring

No. of Cores	Function	Cable Colour
1, 2 or 3	Phase Conductor	Brown
	Neutral Conductor	Blue
	Protection Conductor	Green or Green-Yellow
4 or 5	Phase Conductor	Brown or Black
	Neutral Conductor	Blue
	Protection Conductor	Green or Green-Yellow

Various material and insulation layers are used for conductor protection. Cable selection in accordance to insulation layers must be done correctly for the type of the wiring installation as shown in the table below:

b. Legal Requirements for Installation

- The light fixtures and fittings shall be assembled and installed in position complete and ready for service, in accordance with details, drawings, manufacturer's instructions and to the satisfaction of the construction manager / Consultants.
- Pendant fixtures specified with overall stem lengths are subject to change and shall be checked with conditions on the job and installed as directed. All suspended fixtures shall be mounted rigid and fixed in position in accordance with drawings, instructions and to the approval of the construction manager / consultants.
- Fixtures shall be suspended true to alignment, plumb level and capable of resisting all lateral and vertical forces and shall be fixed as required.
- All suspended light fixtures, fans etc, shall be provided with concealed suspension arrangement in the concrete slab / roof members. It is the duty of the contractor to make these provisions at the appropriate stage of construction.
- Exhaust fans shall be fixed at location shown on drawings. They shall be wired to a

plug socket outlet at a convenient location near the fan.

- All switch and outlet boxes, for fans and light fittings shall be bonded to earth. The recessed type fixtures shall not be supported into the false ceiling frame work. This shall have independent support from the socket of ceiling using conduit down rods / steel chain with provision for adjusting the level of fitting.
- Wires shall be connected to all fixtures through connector blocks. Wires brought out from junction boxes shall be encased in flexible pipes for connecting to fixtures concealed in suspended ceiling.
- The flexible bush, double checkout at the fixture and flexible pipes, wherever used shall be of make and quality approved by the Construction manager / Consultants.

1.1.6 Selection of Wiring Accessories

- All wiring accessories to be used have to be of those approved by the Energy Commission and labeled with labels issued
1. For all wiring using UPVC conduits: -
 - Switches, socket outlets, 3 pin plugs, ceiling roses, connectors, sockets – construction material shall be of polycarbonate type.
 2. For all wiring using metal conduits: -
 - Switches, socket outlets and connectors – construction material shall be of metal clad type, and
 - All accessories shall be effectively earthed.
 3. **Switch fuse** used in single phase installations shall have the fuse permanently connected and not move with the fuse.
 4. **Fuse switch** used in 3 phase domestic installations also has fuse and switch. The fuse connector is installed together to allow the fuse to move simultaneously with the switch.
 5. Lamp:
 - Fluorescent lamps using magnetic ballasts (watt loss not exceeding 6 watts) shall be equipped with dry paper type capacitor;
 - Fluorescent lamps using electronic ballasts or high frequency electronic ballasts do not need capacitors;
 - Outdoor domestic lamp installations shall use weather proof and water proof lamps;
 - Submerged light installations (example in swimming pools, fountains, etc.) shall have water proof lamps with a voltage not exceeding 12 Volt AC.
 6. **Electric water heaters** is divided into 2 types, namely instantaneous water heaters and stored water heaters (storage tank type)
 7. Instantaneous water heaters shall be equipped with a 2 pole control switch and its own residual current device. Storage water heaters (storage tank type) shall be installed with an isolator and its own residual current device; and Water heaters exceeding 3kW shall be permanently connected to a 20A/30A rated circuit breaker/fuse with an isolator switch and residual current device.
 8. **Electric cookers** exceeding 3kW shall have its own circuit connected permanently to a 30A rated circuit breaker or fuse with an isolator switch and cooker control unit

incorporated with a 13A socket outlet. Two or more cooker appliances may be installed in the same room within a distance of 2 meters.

9. **Electric bells** – the circuit shall have a push button switch and a AC/DC transformer.
10. **Ceiling fans** shall conform to clause 21.101 of the MS 1219:2002 standard with regards to test on the suspension system of ceiling fans.

1.1.7 Electric Circuit

In electrical system, we are often interested in communicating or transferring energy from one point to another. To do this requires an interconnection of electrical devices. Such interconnection is referred to as an *electric circuit*, and each component of the circuit is known as an *element*.

In short an **electric circuit** is an interconnection of electrical elements. It is used in numerous electrical systems to accomplish different tasks. The essential parts of an electric circuit consist of a power source, protection device, conductors, control device, and load. A closed circuit is a closed loop or path from one side of a voltage source to the other, as illustrated in Figure 1.6.

A complete or closed circuit is needed for current to flow. If the circuit is broken at any point, there is no longer a closed loop and no current can flow. This is often referred to as an open circuit.

1.2 occupational health and safety standards

Definition: - Follow OH&S policies and procedures for installing and terminating wiring system means follow the correct occupational health safety procedures for safe individual, work area, Tools and equipment from electrical damage. The material that is used to protect individual safety against a risk to health and safety is called PPE (personal protective equipment).

PPE is defined as all equipment designed to be worn, or held, to protect against a risk to health and safety. This includes most types of protective clothing, and equipment such as Goggles- wear of eye, Safety shoes(boot)-wear of foot, Helmet- wears of head, Gloves- wear of hands, Apron- wears of the body, Ear muff- wears of ear, Face mask -wear of face.

Under the Health and Safety at Work Act, employers must provide free of charge any PPE and employees must make full and proper use of it. Safety signs such as those shown at Fig. below are useful reminders of the type of Safety signs





Figure 1.7 Health and Safety Signs

PPE are to be used in a particular area. The vulnerable parts of the body which may need protection are the head, eyes, ears, lungs, torso, hands and feet and, additionally, protection from falls may need to be considered. Objects falling from a height present the major hazard against which head protection is provided. Other hazards include striking the head against projections and hair becoming entangled in machinery. The eyes are very vulnerable to liquid splashes, flying particles and light emissions such as ultraviolet light, electric arcs and lasers. Types of eye protectors include safety spectacles, safety goggles and face shields. Screen-based workstations are being used increasingly in industrial and commercial locations by all types of personnel. Working with VDUs (visual display units) can cause eye strain and fatigue and, therefore, this hazard is the subject of a separate section ‘VDU operation hazards’.

Noise is accepted as a problem in most industries and surprisingly there has been very little control legislation. The Health and Safety Executive have published a ‘Code of Practice’ and ‘Guidance Notes’ for reducing the exposure of employed persons to noise.

Boots or shoes with in-built toe caps can give protection against impact or falling objects and, when fitted with a mild steel sole plate, can also provide protection from sharp objects penetrating through the sole. Special slip resistant soles can also be provided for employees working in wet areas.

1.2.1 Safety

- ❖ Turn the power off at the circuit breaker to the wires you’ll strip or splice.
- ❖ Ensure the power is off by testing the wires.
- ❖ Be careful not to cut into the wire while stripping it.
- ❖ Make sure all splices are secure. Loosely joined wires can cause shorts.

Protective Equipment Personal Protective Equipment (PPE) that might be needed for protection against electric shock includes but is not limited to:

- Nonconductive hard-hats, gloves, and foot protection or insulating mats
- Eye and face protection whenever there is danger from electric arcs or flashes
- Insulated tools or handling equipment
- Protective shields and barriers to protect against electrical shock and burns

1.2.2 Undertaking all work safely and to workplace procedures

In Occupational health and safety legislation, the Occupational Safety and Health specify the following fundamental and generic requirements:

- A) An employer or trainee shall provide and maintain a working environment in which the employees are not exposed to hazards and in particular,
- B) an employer or trainee shall provide such information, instruction, and training to, and supervision of, where it is not practicable to avoid the presence of hazards at the workplace, provide the employees with adequate personal protective clothing and equipment to protect them against those hazards
- C) An employee shall take reasonable care to ensure his or her own health and safety at work;

- D)** A manner in which he or she has been properly instructed to use it; or
- misuses or damages any equipment provided in the interests of safety or health; or fails to report forthwith to the shop assistance or the trainer ;
 - any injury or harm to health of which he or she is aware that arises in the course of, or in connection with, his or her work.
- E)** The Occupational Safety and Health Regulations principally specify detailed requirements for risky or potentially hazardous work activities or hazardous situations, to ensure an adequate level of safety for workers and other persons in the vicinity of the work being performed.

For example, the regulations specify certain safe work practices requirements for work in confined spaces, or for demolition work, or work involving asbestos products.

1.2.3 Workplace Electrical Safety Tips

- Plan every job and think about what could go wrong.
- Use the right tools for the job.
- Use procedures, drawings, and other documents to do the job.
- Isolate equipment from energy sources.
- Identify the electric shock and arc flash, as well as other hazards that may be present.
- Minimize hazards by guarding or establishing approach limitations.
- Test every circuit and every conductor every time before you touch it.
- Use personal protective equipment (PPE) as a last line of defense in case something goes wrong.
- Be sure you are properly trained and qualified for the job.
- Work on electrical equipment and conductors only when de-energized, unless procedures and safeguards have been established to ensure zero exposure for the worker and other people in the area.
- Lockout/tag out and ground (where appropriate) before working on equipment.
- Treat de-energized electrical equipment and conductors as energized until lockout/tag out, test, and ground procedures (where appropriate) are implemented.
- Wear protective clothing and equipment and use insulated tools in areas where there are possible electrical hazards.

Give the correct answer by looking at the socket outlets and cabinets



Figure 1.8 Wall sticker socket

What's wrong here? _____ What's the problem? _____



Figure 1.9 electrical cabinet

Can this cabinet turned back on and create hazards -----

1.3 Required materials and equipment for the tasks

1.3.1 Wire materials

The most common material for electrical wire is copper and aluminum, these are not the best conductors however they are abundant and low cost gold is also used in applications because it is corrosion resistant.

Cable color

Old Cable Colour Code		New Cable Colour Code	
	Single Phase	Three Phase	
Phase Conductor (Line)	Red or Yellow or Blue	Line 1 Red Line 2 Yellow Line 3 Blue	Line 1 Brown Line 2 Black Line 3 Grey
	Neutral Conductor		Blue
	Protective Conductor (Earth)		Green-and-Yellow

Figure 1.10 Cable color

1.3.2 Tools and materials used for connecting/terminating wires

Definition: - Obtain Tools, equipment and testing devices needed to carry out the installation work means identify the hand tools and power tools, equipment and testing instrument that necessary to complete installing the electrical apparatus with good appearance.

Some additional tools required by an electrician engaged in industrial installations.

- ✓ Where special tools are required for example, those required to terminate cables or the bending and cutting tools for conduit and cable trays.
- ✓ They will often be provided by an employer but most hand tools are provided by the electrician himself.
- ✓ In general, good-quality tools last longer and stay sharper than those of inferior quality, but tools are very expensive to buy.
- ✓ A good set of tools can be assembled over the training period if the basic tools are bought first and the extended tool-kit acquired one tool at a time.
 - i. Tools should be cared for and maintained in good condition if they are to be used efficiently and remain serviceable.
 - ii. Screwdrivers: should have a flat squared off end and wood chisels should be very sharp.
 - iii. Wire stripper: that is used to remove insulation from conductor. Steel rule is used to scribe strait line.
 - iv. Long nose pliers, flat screw driver, Phillips screw driver, test light Access to a grind-stone will help an electrician to maintain his tools in first-class condition.
 - v. Additionally, wood chisels will require sharpening on an oilstone to give them a very sharp edge.
- ✓ Tools and Equipment



Figure 1.11 electrical tools and equipment
Pliers (Long Nose, Combination, Diagonal Cutter)

Pliers are available in different types, shape, and sizes. They are also available in both insulated and un-insulated handles. An insulated handle should be used when working on or near hot wires. It is also used for cutting big and small wires.



Figure 1.12 Screw Drivers (Flat (Universal) and Philips)

A screwdriver comes in various sizes and with several tip shapes. Screwdrivers used by electricians should have insulated handles. Using a screwdriver for a particular job, the width of the screwdriver tip should match the width of the screw slot.



Figure 1.13 Drilling Equipment

Drilling equipment is needed to make holes in building structure passages of conduits and wires.



Figure 1.14 Sawing and Cutting Tools

Saws commonly used by electricians include the crosscut, keyhole, and hacksaw.



Figure 1.15 Soldering Equipment

In doing electric wiring, splices and taps (connections made to wire) should be soldered, unless you use solder less connectors. Typical equipment's available for soldering are shown below.



Figure 1.16 Hammers

Hammers are used with chisels and for nailing and fitting. Below are examples of carpenter's claw hammer, lineman's hammer, and machinist's ball-peen hammer



Figure:1.17 Measuring Tools

To measure wire length and other items, the electrician finds considerable use for measuring tools such as the extension or zigzag rule, push-pull rule and a steel tape as shown below.



Figure: 1.18 Knife (Electrician Knife)

You will need to have a good knife, and I prefer a standard utility knife for stripping the PVC jacket from Romex, stripping large gauge wire, and for many other jobs as well.



Figure: 1.19 Wire Strippers

Have a good quality wire stripper. I prefer a T-Stripper with a wire cutter, light-duty pliers nose, and holes for bending termination loops on wires for most home electrical work. A combination crimper, cutter, stripper, bolt cutter and more, like those found in automotive electrical repair kits can be very handy as well, but the multi-purpose aspect means that the wire stripping function is compromised.



Figure 1.20 Fish Tape, and/or Fishing Tools

A fish tape is very handy, and essential if working with conduit. A fish tape or fishing tools are required if you are installing electrical in existing walls or ceilings and are trying to minimize the damage you may cause by cutting as few access holes as possible.



Figure 1.21 Electrical Tape (Insulation Tape)

Every electrical tool kit should have at least a roll of black electrical tape, and having a few colors like red and blue helps as well for identifying wires, etc.



Figure 1.22 Digital Multi-meters (DMM)

Multi-meters are commonly used to measure current, resistance, or voltage. Originally termed analog Volt-Ohm-Millimeter (VOM), some models are referred to as Volt-Ohm Meters (VM). Digital Volt Meters (DVMs) measure voltage (certain oscilloscope models have this capability, as well).



Figure 1.23 Mega-ohmmeters/Insulation Tester

An insulation tester is an ohmmeter that measures the electrical resistance of insulating components. The tester outputs a high DC voltage to generate a current through and over the tested insulation. Readings indicate the amount of current escaping from the insulating material. Since meter resistance values can be displayed in mega ohms, devices are also called mega ohmmeters



Figure 1.24Ammeter (Analog)

An ammeter (from Ampere Meter) is a measuring instrument used to measure the current in a circuit. Electric currents are measured in amperes (A), hence the name. Instruments used to measure smaller currents, in the milliamp or microampere range, are designated as millimeters or micro ammeters. Early ammeters were laboratory instruments which relied on the Earth's magnetic field for operation. By the late 19th century, improved instruments were designed which could be mounted in any position and allowed accurate measurements in electric power systems.



Figure 1.24 A voltmeter

Voltmeter is an instrument used for measuring electrical potential difference between two points in an electric circuit. Analog voltmeters move a pointer across a scale in proportion to the voltage of the circuit; digital voltmeters give a numerical display of voltage by use of an analog to digital converter. A voltmeter in a circuit diagram is represented by the letter V in a circle. In electrical and electronic engineering, a current clamp or current probe is an electrical device with jaws which open to allow clamping around an electrical conductor. This allows measurement of the current in a conductor without the need to make physical contact with it, or to disconnect it for insertion through the probe. Current clamps are typically used to read the magnitude of alternating current (AC) and, with additional instrumentation, the phase and waveform can also be measured. Some clamps meters can measure currents of 1000 A and more. Hall Effect and vane type clamps can also measure direct current (DC).



Figure 1.24 Drill

Drills are commonly used in woodworking, metalworking and construction. A large drill used in construction for drilling out holes needed for the electrical wiring A drill is a tool with a rotating drill bit used for drilling holes in various materials. A drill press (also known as pedestal drill, pillar drill, or bench drill) is a fixed style of drill that may be mounted on a stand or bolted to the floor or workbench. A drill press consists of a base, column (or pillar), table, spindle (or quill), and drill head, usually driven by an induction motor.

1. Wire stripper/ Electrician Pocket knife
2. Soldering Iron
3. Solder Sucker
4. Terminating lug
5. **Electrical Testing devices**

The electrical contractor is charged with a responsibility to carry out a number of tests on an electrical installation and electrical equipment. The individual tests are dealt with in Part 6 of the IEE Regulations and described later in this chapter. The reasons for testing the installation are:

- to ensure that the installation complies with the Regulations,
- to ensure that the installation meets the specification,
- To ensure that the installation is safe to use. Those who are to carry out the electrical tests must first consider the following safety factors:
- An assessment of safe working practice must be made before testing begins.
- All safety precautions must be put in place before testing begins.
- Everyone must be notified that the test process is about to take place, for example the client and other workers who may be affected by the tests.
- ‘Permits-to-Work’ must be obtained where relevant.
- All sources of information relevant to the tests have been obtained.
- The relevant circuits and equipment have been identified.

a. Digital millimeters or instruments

Digital meters provide the same functions as analogue meters but they display the indicated value using a seven-segment LED to give a numerical value of the measurement.



Figure: 1.25 Clamp-on ammeter or Tong tester

The tong tester or clamp-on ammeter works on the same principle as the transformer. The laminated core of the transformer can be opened and passed over the bus bar or single-core cable. In this way a measurement of the current being carried can be made without disconnection of the supply. The construction is shown in Fig. 1.3.16 below



Figure 1.26 Voltmeter

Historical voltmeter from the physics class

- A **voltmeter** is an instrument used for measuring the electrical potential difference between two points in an electric circuit.
- Analog voltmeters move a pointer across a scale in proportion to the voltage of the circuit; digital voltmeters give a numerical display of voltage by use of an analog to digital converter.
- Voltmeters are made in a wide range of styles



Figure 1.27 Voltmeter Schematic Symbol

The voltmeter symbol (V) is shown in the diagram.

a. Ammeter

- An **ammeter** is a measuring instrument used to measure the electric current in a circuit.
- Electric currents are measured in amperes, hence the name.

- The word "ammeter" is commonly misspelled or mispronounced as "ammeter" or "ammeter" by some. Ammeter Schematic Symbol
- The ammeter symbol (A) is shown in the diagram.

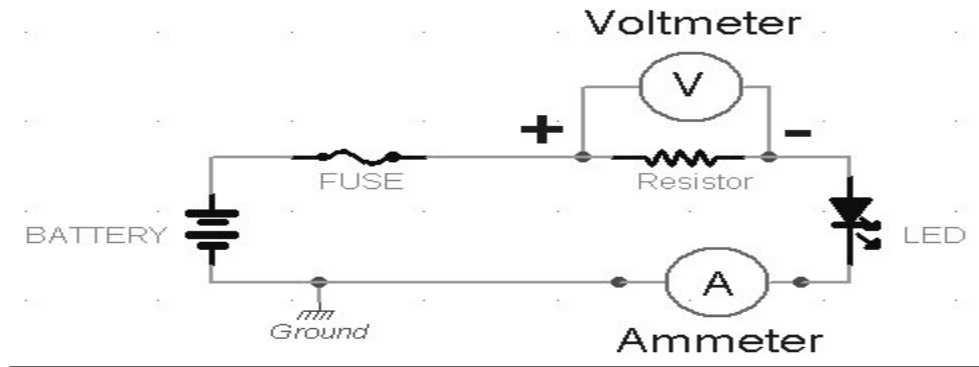

Figure 1.28 circuit

b. Wattmeter

The **wattmeter** is an instrument for measuring the electric power (or the supply rate of electrical energy) in watts of any given circuit.



Figure 1.29 Wattmeter

1.3.3 Wiring enclosures and equipment

Electrical equipment: any item for such purposes as generation, conversion, transmission, distribution or utilization of electrical energy, such as machines, transformers, apparatus, measuring instruments, protective devices, wiring materials, accessories, appliances and luminaries.

Enclosure: a part providing an appropriate degree of protection of equipment against certain external influences and a defined degree of protection against contact with live parts from any direction.

SELV: an extra-low voltage system which is electrically separated from Earth and from other systems in such a way that a single fault cannot give rise to the risk of electric shock.

Identifying and Selecting the Wiring Materials and Components

Wiring materials

Electrical wire is made of materials like copper, aluminum and silver. As silver is expensive, mostly copper and aluminum are used in wiring.

Materials are classified into three types according to their properties:

Page 30 of 102	Ministry of Labor and Skills Author/Copyright	Apply Basic Electrical Practices	Version -1 August 2022
----------------	--	----------------------------------	---------------------------

- a. Conducting materials
- b. Insulating materials
- c. Semiconductor materials

Conducting Material

(a) **Copper:** It is a good conductor of electricity. It is used in wiring materials in cables. It has low resistance and is used for conduction of electricity at high, medium and low voltage Figure 1.20 It is used in wiring and cable making.



Figure 1.20 Copper wires

(b) **Aluminum:** It is light weight and cheaper in comparison to copper. Therefore, this type of conducting material is mostly used in electrical wiring. It is silvery–white in color and it has a soft texture. It is often used in wiring and making cable Figure 1.21



Figure 1.21 Aluminum Conductors

1.3.4 Electrical Cables

Electrical cables are used to carry electric currents. Most cables are constructed in three parts:

- a. The conductor that carries the current and may have a stranded or solid core.
- b. The insulation, that contains the current and is color coded for identification.
- c. The outer sheath that may contain some means of providing protection from mechanical damage.

Figure 1.22 shows PVC insulated and sheathed cable. The type used for domestic installations.

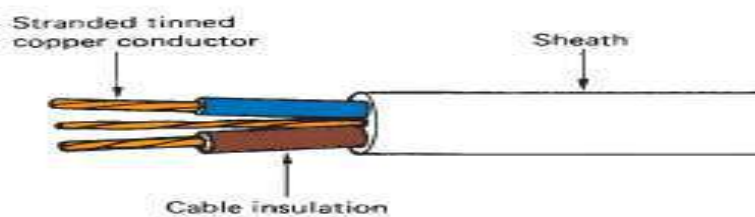

Figure 1.22 PVC insulated and sheathed cable

1.3.5 Insulating Materials

Insulating materials are used for insulating purpose. These types of materials are bad conductors of current. For example: rubber, paper, mica, wood, glass and cotton.

a) Wiring Accessories

Wiring accessories are used for connecting appliances (Figure 1.22)



Figure 1.23 wiring accessories

b. Switch: A switch is used to make or break an electrical circuit. It is used to switch ‘on’ or ‘off’ the supply of electricity to an appliance. There are various switches such as

1. surface switch
2. flush switch
3. ceiling switch
4. pull switch
5. push button switch
6. bed switch

c. Surface switch: It is mounted on wooden boards fixed on the surface of a wall. It is of three types

- a. One-way switch
- b. Two-way switch
- c. Intermediate switch

a. One-way switch: It is used to control single circuits and lamp/s from one location. It consists of two connection terminals (one terminal phase for life/hot wire and one for Return wire which connected to lamp).



Figure 1.24 one way switch pictorial diagram and symbol

b. Two-way switch: It is used to divert the flow of current to either of two directions. The two-way switch can also be used to control one lamp from two different places/locations.

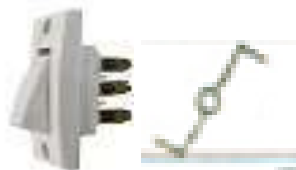

Figure 1.25 two way switch pictorial diagram and symbol

c. Intermediate switch: It is used to control a lamp from more than two locations with interconnection of 2 two way switches at right and left side and intermediate switch in between.



Figure 1.26 Intermediate switch pictorial diagram and symbol

(d) **Holders:** Is used to hold the lamps. A holder is of two types.



Figure 1.27 types of lamp holders

(e) **Ceiling rose:** It is used to provide a tapping to the pendant lamp–holder through the flexible wire or a connection to a fluorescent tube.



Figure 1.28 Ceiling rose

(f) **Socket outlet/plug:**-The socket outlet has an insulated base with the molded or socket base having three terminal sleeves



Figure 1.29 Socket out let

(g) **Main switch:** To control the electrical circuit a main switch is used. Through the main switch, the power in a building is controlled completely



Figure1.30 Main Switch/Main MCB

Cartridge Fuses (BS 1361)

The cartridge fuse breaks a faulty circuit in the same way as a semi-enclosed fuse, but its construction eliminates some of the disadvantages experienced with an open-fuse element. The fuse element is encased in a glass or ceramic tube and secured to end-caps which are firmly attached to the body of the fuse so that they do not blow off when the fuse operates. Cartridge fuse construction is illustrated in Figure 1.31 with larger size cartridge fuses, lugs or tags are sometimes brazed on the end-caps to fix the fuse cartridge mechanically to the carrier. They may also be filled with quartz sand to absorb and extinguish the energy of the arc when the cartridge is brought into operation.

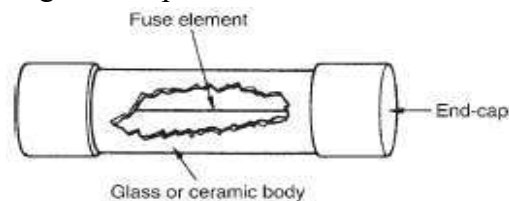

Figure 1.31 Cartridge fuse

Miniature Circuit Breakers (BS 3871)

The disadvantage of all fuses is that when they have operated they must be replaced. An MCB overcomes this problem since it is an automatic switch which opens in the event of an excessive current flowing in the circuit and can be closed when the circuit returns to normal. An MCB of the type shown in Figure 1.32 incorporates a thermal and magnetic tripping device. The load current flows through the thermal and the electromagnetic devices in normal operation but under over current conditions they activate and trip the MCB. The circuit can be restored when the fault is removed by pressing the ON toggle. This latches the various mechanisms within the MCB and ‘makes’ the switch contact. The toggle switch can also be used to disconnect the circuit for maintenance or isolation or to test the MCB for satisfactory operation.



Figure 1.32 MCBs Breaker.

The IEE Regulations state that the protective device must operate very quickly to remove the danger and within a time of:

- ❖ 0.4 seconds for portable equipment supplied by socket outlet circuits
- ❖ 5.0 seconds for fixed equipment
- ❖ 0.2 seconds for construction sites, agricultural and horticultural premises

1.4 Interpreting relevant plans, drawings and texts

1.4.1 Layout and Installation Drawing

- 1) The electrical layout should be considered after proper locations of all outlets for lamps, fans, appliances - both fixed and transportable, motors, etc, have been selected and best methods of wiring determined.
- 2) All runs of wiring and exact positions of all points of switch-boxes and other outlets shall be first marked on the plans of the building and approved by the engineer in charge or the owner before the actual commencement of the work.

1.4.2 Marking of equipment

Each piece of electrical equipment shall bear such of the following markings as may be necessary to identify the equipment and ensure that it is suitable for the particular installation:

- The maker's name, trademark, or other recognized symbol of identification.
- Catalogue number or type.
- Voltage.
- Rated load amperes.
- Watts, volt-amperes, or horsepower.
- Whether for a.c., d.c., or both.
- Number of phases.

- Frequency in Hertz.
- Rated load speed in revolution per minute.
- D Designation of terminals.
- Whether for continuous or intermittent duty.
- Evidence of approval.
- Such other marking as may be necessary to ensure safe and proper operation

Each service box, at the time of installation, shall be marked in a conspicuous, legible, and permanent manner to indicate clearly the maximum rating of the over current device which may be used for this installation. At each distribution point, circuit breakers, fuses, and switches shall be marked, adjacent thereto, in a conspicuous and legible manner to indicate clearly:

- a) which installation or portion of installation they protect or control;
- b) The maximum rating of over current device that is permitted.

Checking materials for correct specifications

Receiving and checking incoming materials involves:

1. Working with minimum supervision
2. Preparation of work area for receipt of materials
3. Receiving materials
4. Confirming the status of the materials
5. Resolving problem within the limits of your responsibility
6. Completing any necessary documentation accurately and legibly
7. Working in ways which maintain the safety of yourself and others

1.4.3 Interpreting electrical Diagrams and drawings

Site Plans or Layout Drawings: These are scale drawings based upon the architect's site plan of the building and show the position of the electrical equipment which is to be installed. The electrical equipment is identified by a graphical symbol. The standard symbols used by the electrical contracting industry are those recommended by the British Standard EN 60617, Graphical Symbols for Electrical Power, Telecommunications and Electronic Diagrams. Some of the more common electrical installation symbols are given in The Layout drawing or site plan of a small domestic extension is shown in Figure 1.33 It can be seen that the mains intake position, probably a Consumer Unit, is situated in the store-room which also contains one light controlled by a switch at the door. The bathroom contains one lighting point controlled by a one-way pull switch at the door. The kitchen has two doors and a switch is installed at each door to control the fluorescent luminaries. There are also three double sockets situated around the kitchen. The sitting room has a two-way switch at each door controlling the center lighting point. Two wall lights with built-in switches are to be wired, one at each side of the window. Two double sockets and one switched socket are also to be installed in the sitting room. The bedroom has two lighting points controlled independently by two one-way switches at the door.

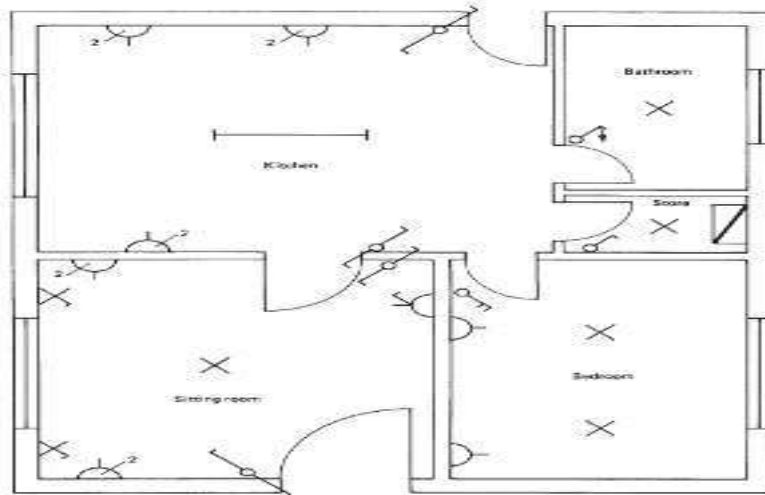

Figure 1.33 Layout drawing or site plan of a small electrical installation

1.4.4 Detail Drawings and Assembly Drawings:

These are additional drawings produced by the architect to clarify some point of detail. For example, a drawing might be produced to give a fuller description of a suspended ceiling arrangement or the assembly arrangements of the metalwork for the suspended ceiling.

1.4.5 Location Drawings: Location drawings identify the place where something is located. It might be the position of the manhole covers giving access to the drains. It might be the position of all water stop taps or the position of the emergency lighting fittings. This type of information may be placed on a blank copy of the architect's site plan or on a supplementary drawing.

1.4.6 Block Diagrams: A block diagram is a very simple diagram in which the various items or pieces of equipment are represented by a square or rectangular box. The purpose of the block diagram is to show how the components of the circuit relate to each other and, therefore, the individual circuit connections are not shown. Figure 1.4.6 shows the block diagram of Light circuit control.



Figure 1.34 Block diagram

1.4.7 Wiring Diagrams:

A wiring diagram or connection diagram shows the detailed connections between components or items of equipment. They do not indicate how a piece of equipment or circuit works. The purpose of a wiring diagram is to help someone with the actual wiring of the circuit. Figure 1.35 shows the wiring diagram for a space heating control system

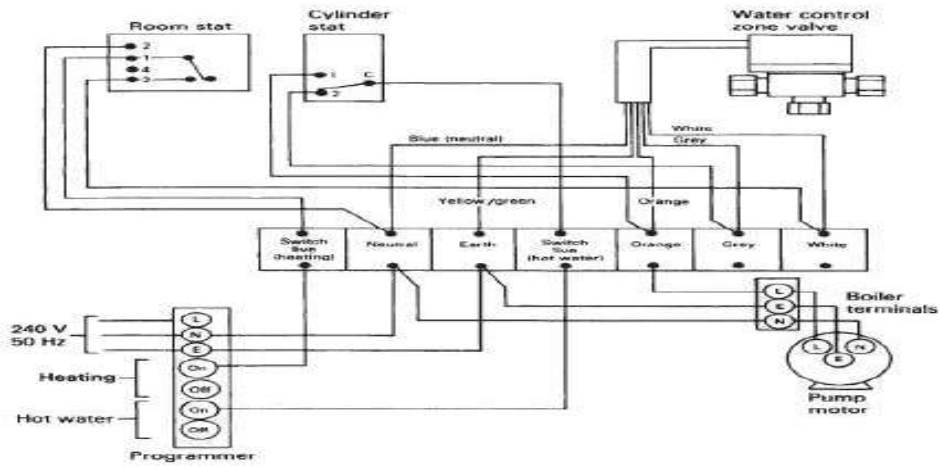

Figure 1.35 Wiring diagram of space heating control system (Honeywell Y. Plan)

1.4.8 Circuit Diagrams: A circuit diagram shows most clearly how a circuit works. All the essential parts and connections are represented by their graphical symbols. The purpose of a circuit diagram is to help our understanding of the circuit.

It will be laid out as clearly as possible, without regard to the physical layout of the actual components and, therefore, it may not indicate the most convenient way to wire the circuit. Figure 1.36 shows the circuit diagram of our same space heating control system.

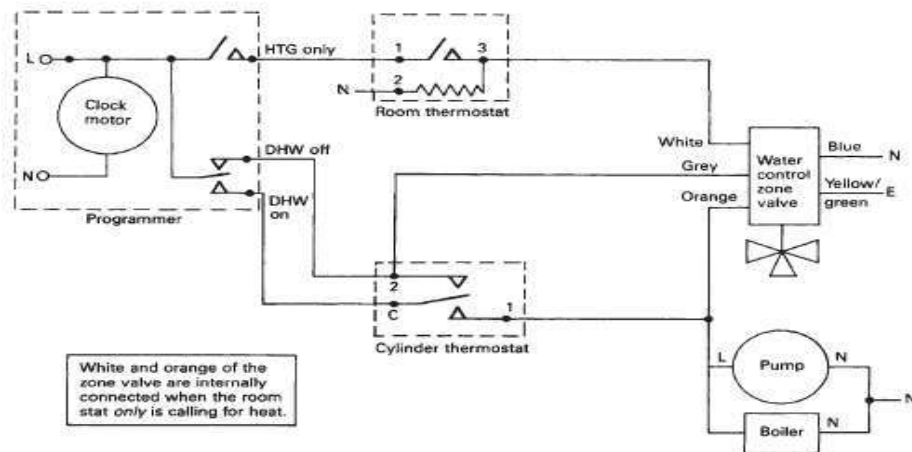

Figure 1.36 Circuit diagram of space heating control system (Honeywell Y. Plan)

1.4.9 Schematic Diagrams

A schematic diagram is a diagram in outline of, for example, a motor starter circuit. It uses graphical symbols to indicate the inter-relationship of the electrical elements in a circuit. These help us to understand the working operation of the circuit but are not helpful in showing us how to wire the components. An electrical schematic diagram looks very like a circuit diagram

1.4.10 freehand Working Diagrams

Freehand working drawings or sketches are another important way in which we communicate our ideas. A freehand sketch may be done as an initial draft of an idea before a full working drawing is made. It is often much easier to produce a sketch of your ideas or intentions than to describe them or produce a list of instructions. To convey the message or

information clearly it is better to make your sketch large rather than too small. It should also contain all the dimensions necessary to indicate clearly the size of the finished object depicted by the sketch.

1.5 Set-up work plan in detail

Methods of setting work, cutting to length and installing wiring systems Conductor splices and connections are an essential part of any electrical circuit. When conductors join each other or connect to a load, splices or terminals must be used. Therefore, it is important that they be properly made. Any electrical circuit is only as good as its weakest link. The basic requirement of any splice or connection is that it is both mechanically and electrically as sound as the conductor or device with which it is used. Quality workmanship and materials must be used to ensure lasting electrical contact, physical strength, and insulation. The most common methods of making splices and connections in electrical cables is explained in the discussion that follows.

1.5.1 General Wire-Stripping Instructions

When stripping wire with any of the tools mentioned, observe the following precautions:

- a. Do not attempt to use a hot-blade stripper on wiring with glass braid or asbestos insulation. These insulators are highly heat resistant.
- b. When using the hot-blade stripper, make sure the blades are clean. Clean the blades with a brass wire brush as necessary.
- c. Make sure all stripping blades are sharp and free from nicks, dents, and so forth.
- d. When using any type of wire stripper, hold the wire perpendicular to the cutting blades.
- e. Make sure the insulation is clean-cut with no frayed or ragged edges; trim if necessary.
- f. Make sure all insulation is removed from the stripped area. Some types of wire are supplied with a transparent layer between the conductor and the primary insulation. If this is present, remove it.
- g. When the hand strippers are used to remove lengths of insulation longer than 3/4 inch, the stripping procedure must be done in two or more operations. The strippers will only strip about 3/4 inch at one time.
- h. Re-twist strands by hand, if necessary, to restore the natural lay and tightness of the strands.
- i. Strip aluminum wires with a knife as described earlier. Aluminum wire should be stripped very carefully. Care should be taken not to nick the aluminum wire as the strands break very easily when nicked.

1.5.2 Insulation Removal

The preferred method of removing insulation is with a wire-stripping tool, if available. A sharp knife may also be used. Other typical wire strippers in use in the Navy are illustrated in figure 1.36. The hot blade, rotary, and bench wire strippers (views A, B, and C, respectively) are usually found in shops where large wire bundles are made. When using any of these automatic wire strippers, follow the manufacturer's instructions for adjusting the machine; this avoids nicking, cutting, or otherwise damaging the conductors.

The hand wire strippers are common hand tools found throughout the Navy. The hand wire strippers (view D of Figure 1.36) are the ones you will most likely be using. Wire strippers vary in size according to wire size and can be ordered for any size needed.

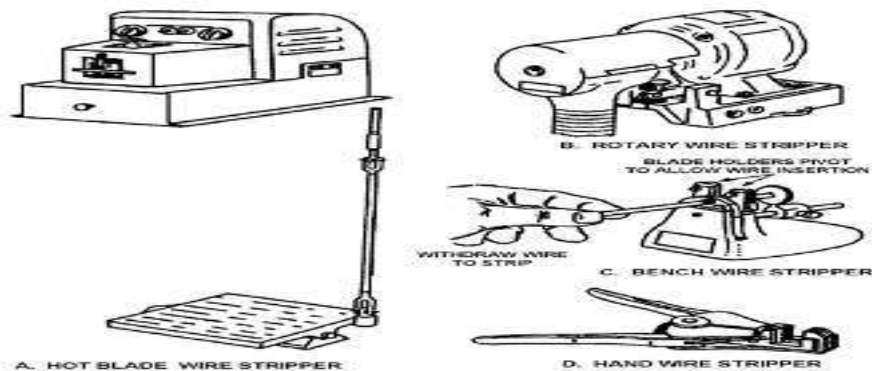

Figure 1.36 Typical wire-stripping tools.

The procedure for stripping wire with the hand wire stripper is as follows refer to Figure 1.37

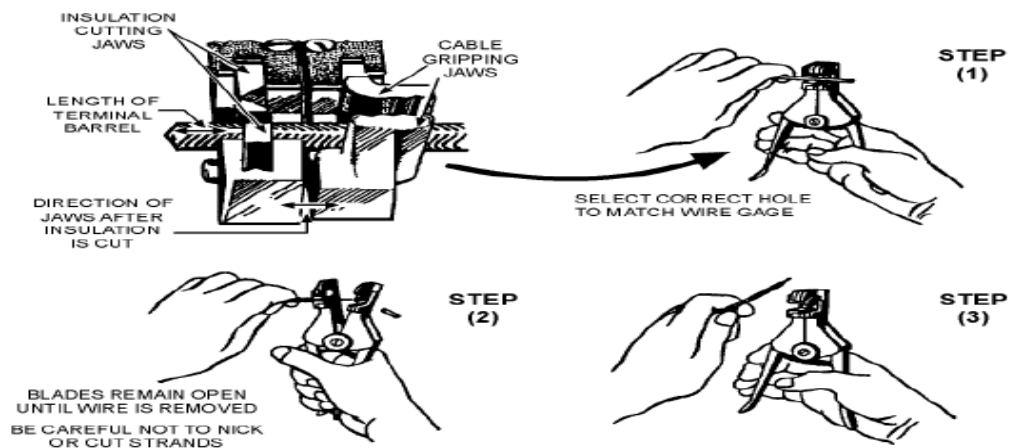

Figure 1.37 stripping wire with a hand stripper

1. Insert the wire into the center of the correct cutting slot for the wire size to be stripped. The wire sizes are listed on the cutting jaws of the hand wire strippers beneath each slot.
2. After inserting the wire into the proper slot, close the handles together as far as they will go.
3. Slowly release the pressure on the handles so as not to allow the cutting blades to make contact with the stripped conductor. On some of the newer style hand wire strippers, the cutting jaws have a safety lock that helps prevent this from happening. Continue to release pressure until the gripper jaws release the stripped wire, and then remove.

b. Knife Stripping

A sharp knife may be used to strip the insulation from a conductor. The procedure is much the same as for sharpening a pencil. The knife should be held at approximately a 60° angle to the conductor. Use extreme care when cutting through the insulation to avoid nicking or cutting the conductor. This procedure produces a taper on the cut insulation as shown in figure 1.38



Figure 1.38 Knife stripping.

C. Locally Made Hot-Blade Wire Stripper

If you are required to strip a large number of wires, you can use a locally made hot-blade stripper (figure 1.39) as follows:

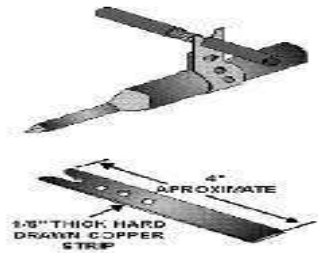

Figure 1.39 locally made hot-blade stripper.

1. In the end of a piece of copper strip, cut a sharp-edged "V." At the bottom of the "V," make a wire slot of suitable diameter for the size wire to be stripped.
2. Fasten the copper strip around the heating element of an electric soldering iron as shown in
3. Figure 1.39 the iron must be rated at 100 watts or greater in order to transfer enough heat to the copper strip to melt the wire insulation.
4. Lay the wire or cable to be stripped in the "V"; a clean channel will be melted in the insulation. Remove the insulation with a slight pull.

1.5.3 Types of Splices

There are six commonly used types of splices. Each has advantages and disadvantages for use. Each splice will be discussed in the following section.

1. Western Union Splice

The Western Union splice joins small, solid conductors. Figure 1.40 shows the steps in making a Western Union splice.

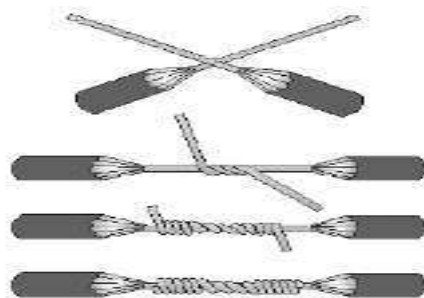

Figure 1.40 Western Union splice.

- a) Prepare the wires for splicing. Enough insulation is removed to make the splice. The conductor is cleaned.
- b) Bring the wires to a crossed position and make a long twist or bend in each wire.
- c) Wrap one end of the wire and then the other end four or five times around the straight portion of each wire.
- d) Press the ends of the wires down as close as possible to the straight portion of the wire. This prevents the sharp ends from puncturing the tape covering that is wrapped over the splice..

2. Staggering Splices

Joining small multi-conductor cables often presents a problem. Each conductor must be spliced and taped. If the splices are directly opposite each other, the overall size of the joint becomes large and bulky.

A smoother and less bulky joint can be made by staggering the splices. Figure 1.41 shows how a two-conductor cable is joined to a similar size cable by using a Western Union splice and by staggering the splices. Care should be taken to ensure that a short wire from one side of the cable is spliced to a long wire, from the other side of the cable. The sharp ends are then clamped firmly down on the conductor. The figure shows a Western Union splice, but other types of splices work just as well.

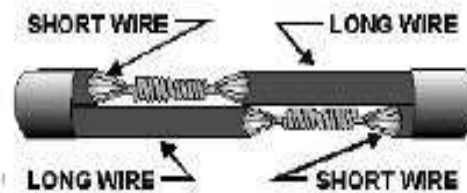

Figure 1.41 Staggering splices.

3. Rattail Splice

A splice that is used in a junction box and for connecting branch circuits is the rattail joint (figure 1.42).



Figure 1.42 Rattail joint.

To create a rattail joint, first strip the insulation off the ends of the conductors to be joined. You then twist the wires to form the rattail effect. This type of splice will not stand much stress.

Fixture Joint .The fixture joint is used to connect a small-diameter wire, such as in a lighting fixture, to a larger diameter wire used in a branch circuit. Like the rattail joint, the fixture joint will not stand much strain.

Figure 1.43 shows the steps in making a fixture joint. The first step is to remove the insulation and clean the wires to be joined. After the wires are prepared, the fixture wire is wrapped a few times around the branch wire. The end of the branch wire is then bent over the completed turns. The remainder of the bare fixture wire is then wrapped over the bent branch wire. Soldering and taping completes the job.

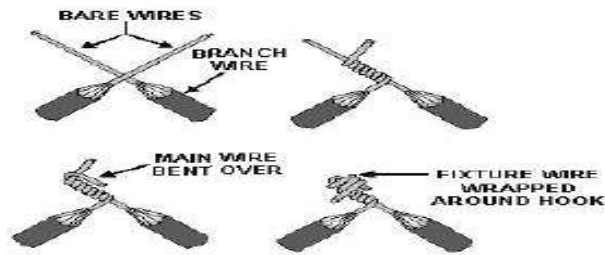

Figure 1.43 Fixture joint.

i. Knotted Tap Joint

All the splices discussed up to this point are known as butted splices. Each was made by joining the free ends of the conductors together. Sometimes, however, it is necessary to join a branch conductor to a continuous wire called the main wire. Such a junction is called a tap joint.

The main wire, to which the branch wire is to be tapped, has about 1 inch of insulation removed. The branch wire is stripped of about 3 inches of insulation. The knotted tap is shown in Figure 1.54

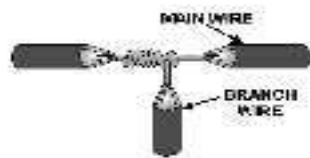

Figure 1.54 Knotted tap joint.

The branch wire is laid behind the main wire. About three-fourths of the bare portion of the branch wire extends above the main wire. The branch wire is brought under the main wire, around itself, and then over the main wire to form a knot. The branch wire is then wrapped around the main conductor in short, tight turns; and the end is trimmed off. The knotted tap is used where the splice is subject to strain or slippage. When there is no strain, the knot may be eliminated.

1.5.4 Splice Insulation

The splices we have discussed so far are usually insulated with tape. The following discussion will cover some characteristics of rubber, friction, and plastic insulation tapes.

i. Rubber Tape: Latex (rubber) tape is a splicing compound. It is used where the original insulation was rubber. The tape is applied to the splice with a light tension so that each layer presses tightly against the one beneath it. This pressure causes the rubber tape to blend into a solid mass. Upon completion, insulation similar to the original is restored. In roll form, there

is a layer of paper or treated cloth between each layer of rubber tape. This layer prevents the latex from fusing while still on the roll. The paper or cloth is peeled off and discarded before the tape is applied to the splice.

The rubber splicing tape should be applied smoothly and under tension so no air space exists between the layers. Start the first layer near the middle of the joint instead of the end. The diameter of the completed insulated joint should be somewhat greater than the overall diameter of the original wire, including the insulation.

- ii. **Warning:** Some rubber tapes are made for special applications. These types are semiconducting and will pass electrical current, which presents a shock hazard. These types of tape are packaged similar to the latex rubber tape. Care should be taken to insulate splices only with latex rubber insulating tape.
- iii. **Friction Tape:** Putting rubber tape over the splice means that the insulation has been restored to a great degree. It is also necessary to restore the protective covering. Friction tape is used for this purpose. It also provides a minor degree of electrical insulation.

Friction tape is a cotton cloth that has been treated with a sticky rubber compound. It comes in rolls similar to rubber tape except that no paper or cloth separator is used. Friction tape is applied like rubber tape; however, it does not stretch. The friction tape should be started slightly back on the original insulation. Wind the tape so that each turn overlaps the one before it. Extend the tape over onto the insulation at the other end of the splice. From this point, a second layer is wound back along the splice until the original starting point is reached. Cutting the tape and firmly pressing down the ends completes the job. When proper care is taken, the splice and insulation can take as much abuse as the rest of the original wire.

- iv. **Plastic Electrical Tape:** Plastic electrical tape has come into wide use in recent years. It has certain advantages over rubber and friction tape. For example, it can withstand higher voltages for a given thickness. Single thin layers of certain plastic tape will withstand several thousand volts without breaking down. However, to provide an extra margin of safety, several layers are usually wound over the splice. The extra layers of thin tape add very little bulk. The additional layers of plastic tape provide the added protection normally furnished by friction tape.

Plastic electrical tape usually has a certain amount of stretch so that it easily conforms to the contour of the splice.

v. conduit Wiring System

Conduit wiring system consists of either VIR or PVC cables taken through tubes or pipes and terminated at the outlets or switches / sockets. The tube or pipe is known as “conduit”. Conduit wiring may run over the surface of the walls and ceiling or may be concealed under masonry work. Electrical conduits are used to protect and provide the route of electrical wiring in an electrical system. Electrical conduits are made of metal, plastic, or fiber and can be rigid or flexible. Conduits must be installed by electricians as per standard regulations.

For workshops and public buildings, conduit wiring is the best and most desirable system of wiring. It provides protection and safety against fire

a) Legal Requirements for conduit installation

- All non-metallic conduit pipes and accessories shall be of suitable material complying with IS: 2509-1973 and IS: 3419-1989 for rigid conduits and IS:9537 (Part 5) 2000 for

flexible conduits. The interior of the conduits shall be free from obstructions. The rigid conduit pipes shall be ISI marked.

- The conduits shall be circular in cross-section. The conduits shall be designated by their nominal outside diameter. The dimensional details of rigid non-metallic conduits are given in Table-II.
- No non-metallic conduit less than 20 mm in diameter shall be used.

Table 6 Wiring capacity Maximum capacities of conduits for drawing in of PVC insulated cables shall be as follows:

650/1100V PVC copper wire	In 20 mm dia conduit	In 25 mm dia conduit	In 32 mm dia conduit
1.5 sq.mm	4	8	12
2.5 sq.mm	3	6	10
4.0 sq.mm	2	6	8
6.0 sq.mm		5	7
6.0 sq.mm		3	5

b) Legal Requirements Conduit Accessories

- The conduit wiring system shall be complete in all respect including accessories.
- Rigid conduit accessories shall be normally of grip type.
- Flexible conduit accessories shall be of threaded type.
- Bends, couplers etc shall be solid type in recessed type of works, and may be solid or inspection type as required, in surface type of works.
- Saddles for fixing conduits shall be heavy gauge non-metallic type with base.
- The minimum width and the thickness of the ordinary clips or girder clips shall be as per Table-III.
- For all sizes of conduit, the size of clamping rod shall be 4.5 mm diameter.

c) Separate conduit shall be used for:

- Normal/light, fan, call bell and general purpose socket outlets
- Power outlets
- Emergency lighting and power
- Telephone
- Fire Alarm System
- Public address system
- Computer System

1.5.5 Types of Conduits

- Rigid steel / metal conduit.
- Rigid PVC / non-metallic conduit.**
- Flexible steel conduit.
- Flexible PVC / non-metallic conduit.**

Non-Metallic or PVC conduits are cheaper than metal conduits.

Concealed or Recessed Conduit Wiring:

The conduits (metal or PVC) are embedded along walls or ceiling in plaster at the time of building construction. The conduits are fixed by means of saddles or staples not more than 60

cm. apart. Fixing of bends or elbows should be avoided as far as possible. All curves should be made by bending the conduit pipe itself to permit easy drawing in of cables. The VIR or PVC cables are drawn into the concealed by means of springs or GI wire of size 18 SWG. Suitable inspection boxes should be provided to permit periodical inspection, drawing of cables and to facilitate removal of cables if necessary. The inspection boxes should be mounted flush with the wall. Now a day's PVC conduits are increasingly being used in place of steel conduits. PVC conduits are less expensive and the labor time saved may be as much as 25% to 50% compared to the time taken when installing steel conduits. PVC conduits are resistant to acids alkalis, oil and moisture. They can be buried in lime or cement plaster without ill effects. Concealed conduit wiring is used in residential, commercial and public buildings.

PVC casing-capping wiring

PVC capping is done in order to cover the wires. It includes casing also. This casing-capping wiring is also known as open wiring, as it is done outside the wall. Materials required for PVC casing-capping wiring

1. Wire
2. Casing enclosures made up of plastic
3. Capping made up of plastic
4. T. Joints VIR (Vulcanized Indian Rubber) or PVC (Polyvinyl chloride) insulated wire
 - Junction box
 - Elbow
 - Casing and capping joints

Wooden casing-capping wiring is old fashioned. Now PVC or VIR insulated wires are enclosed within the PVC casing enclosure and PVC capping is used to cover the casing.



Figure 1.55 Casing Capping Accessories



Figure 1.56 Casing Capping Bend



Figure 1.57 Junction Boxes

Advantages of casing-capping wiring

- Easy to install
- Strong and durable wiring
- Customization can be done easily

- Safe from smoke, dust, rain and steam, etc.
- No risk of shock due to casing and capping,

Disadvantages of PVC casing-capping wiring

- Costly
- Not suitable for humid weather
- High risk of fire

1.5.6 Lighting circuits

- **Ohm's Law**

Ohm's law states that, in an electrical circuit, the current passing through most materials is directly proportional to the potential difference applied across them.

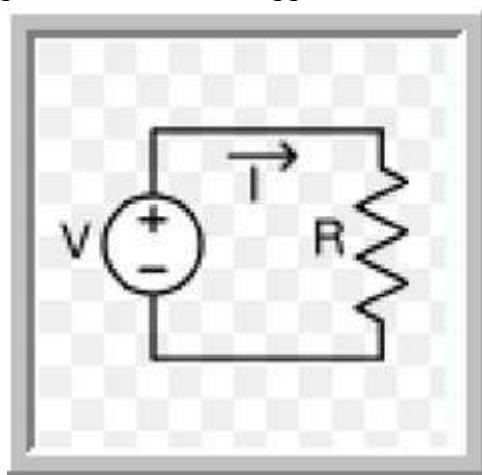

Figure1.58 circuit forms Ohm'

- **Ohm's Law Formulas**

There are three forms of Ohm's Law:

✓ $I = V/R$

✓ $V = IR$

✓ $R = V/I$

where:

$$I = \text{Current} , V = \text{Voltage} , R = \text{Resistance}$$

A circle diagram to help in memorizing the Ohm's Law formulas $V = IR$, $I = V/R$, and $R = V/I$. The V is always at the top

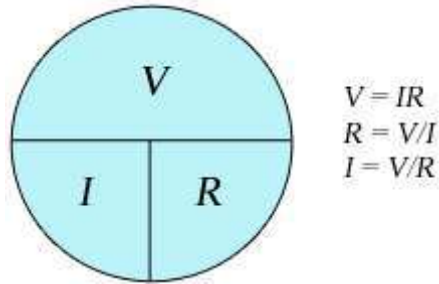

Figure 1.59

In practical unites this law may be stated as amperes =volts/ohms Increasing the applied voltage V produces more current I to light the bulb with more intensity.

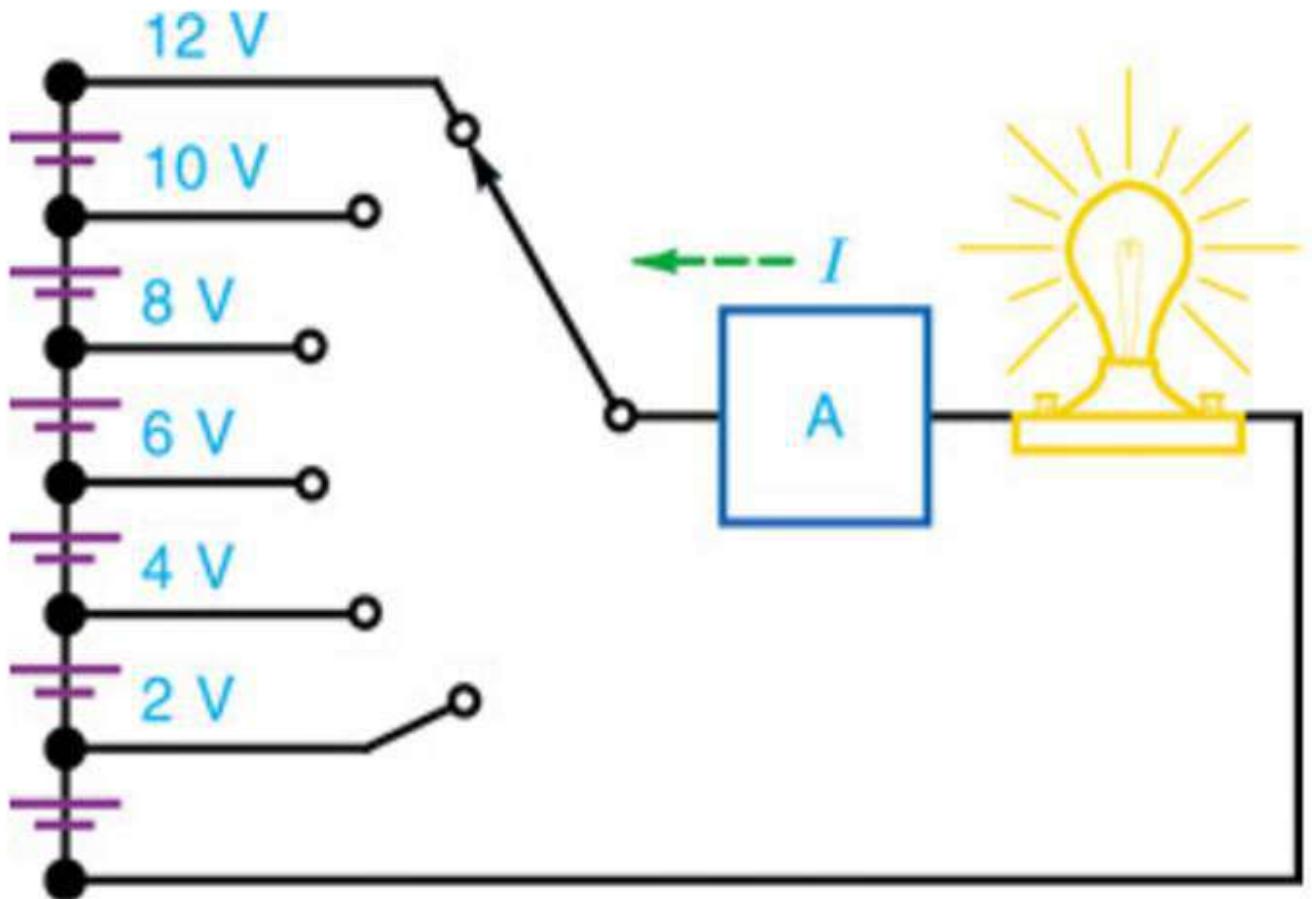

Figure 1.60 rules for ohm

The three forms of Ohm's law can be used to define the practical units of current voltage, and resistance:

$$1 \text{ ampere} = 1 \text{ volt} / 1 \text{ ohm}$$

1 volt = 1 ampere × 1 ohm
1 ohm = 1 volt / 1 ampere

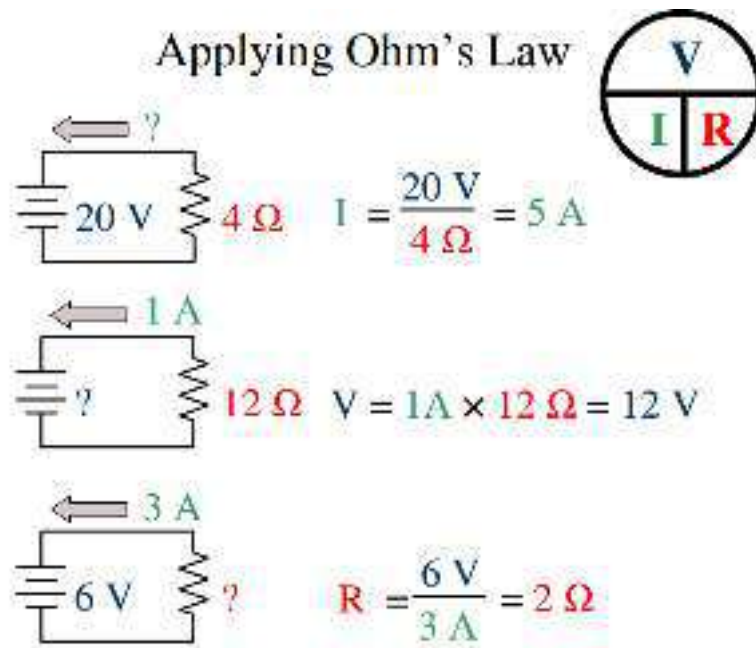

Figure 1.61

One-way switching: Figure 1.62 is a circuit diagram showing how the light or lights are controlled, while Fig. 1.63 shows how the point would be wired in practice.

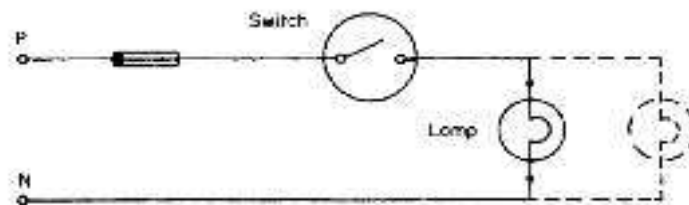

Figure 1.62

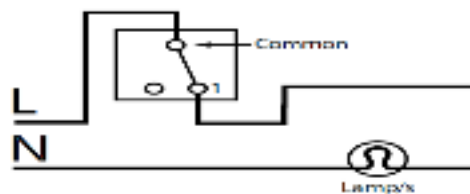

Figure 1.63

Figure 1.63 Single switches controlling one or more lamps (circuit diagram). Note: switch in phase conductor

Points to note

- a) 1 The ends of black, blue or yellow switch wires have red slaving to denote phase conductor. (This is not required for conduit wiring as the cable will be red.)
- b) The earth wire terminations have green and yellow slaving. (This is not required for conduit.)

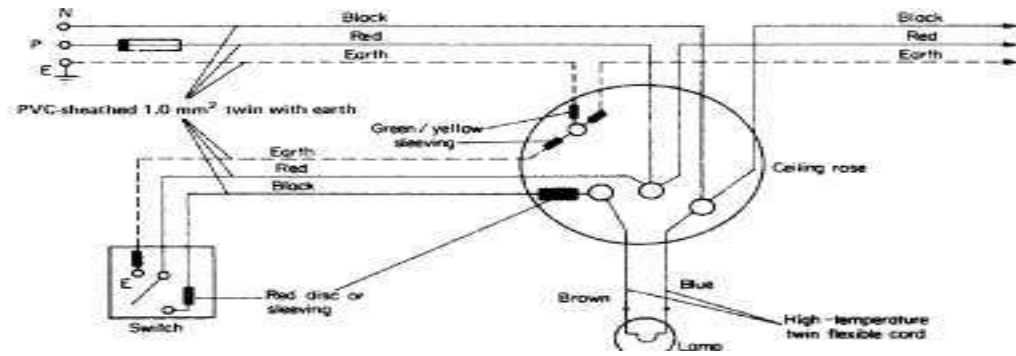

Figure 1.64 Wiring diagram

The light-switch point has an earth terminal.

- c) The ceiling rose has an earth terminal.
- d) The flexible cord from the rose to the lamp holder is capable of withstanding the maximum likely temperature.
- e) If a batten holder is used instead of a ceiling rose, the cable entries should be sleeved with heat-resistant slaving.
- f) The maximum mass suspended by flexible cord shall not exceed:
 - 2 kg for a 0.5mm² cord;
 - 3 kg for a 0.75mm² cord;
 - 5 kg for a 1.0mm² cord.
- g) The phase terminal in a ceiling rose must be shrouded.
- h) For the purpose of calculating the cable size supplying a lighting circuit, each lighting point must be rated at a minimum of 100W. 10 A ceiling rose, unless otherwise designed, must accommodate only one flexible cord.

Two-way switching: A typical application is for two location control

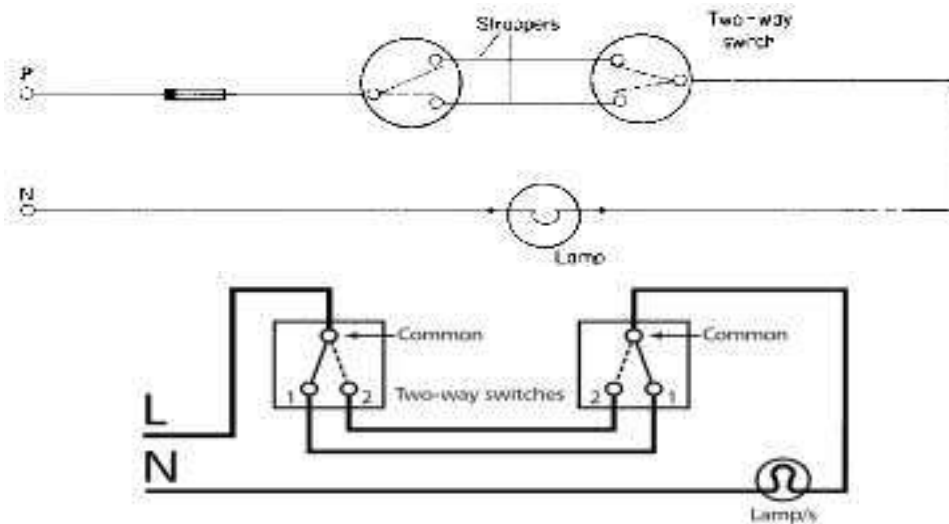

Figure 1.65 Circuit diagram – two-way Switching

Dotted lines show alternative switch positions

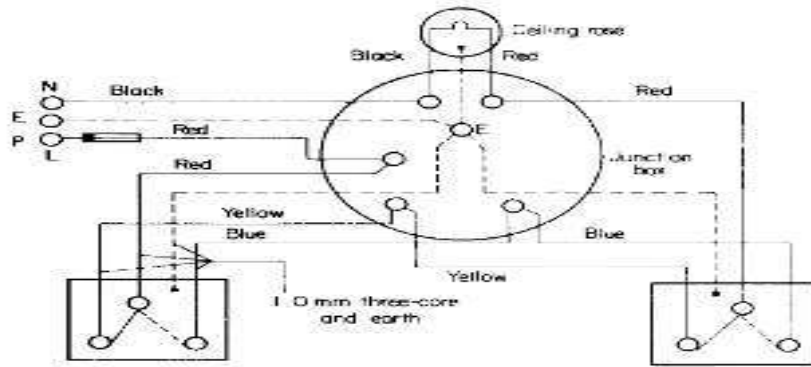

Figure. 1.66 wiring diagram – two-way switching

Two-way and intermediate switching: The circuit diagram for two-way and intermediate switching is shown in Figure 1.67 the earth is omitted from the diagram, for clarity.

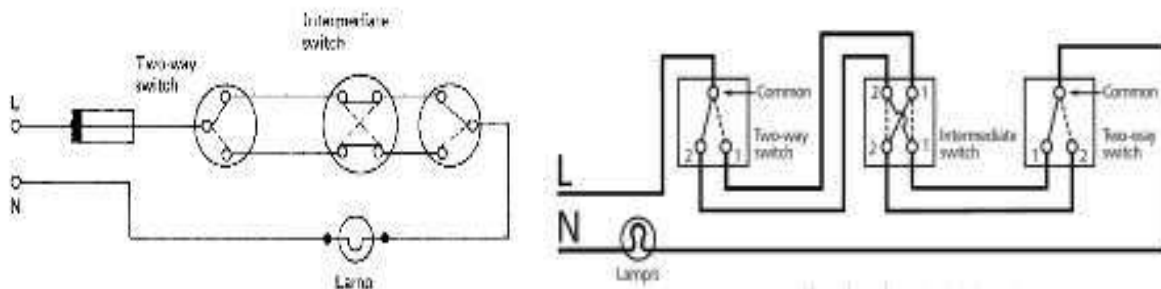

Figure 1.67 Note Circuit diagram – two-way and intermediate switching

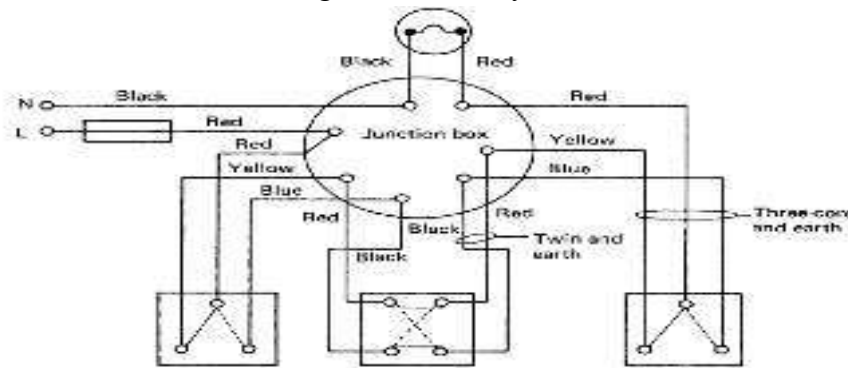

Figure 1.68 wiring diagram (PVC sheathed)

Red sleeping or discs are used on yellow, black and blue cables from two way and intermediate switches to the junction box in order to denote live cables (Figure1.68). The applications of this type of switching are for stairs and landings and in long corridors.

1.5.7 Lighting layouts

There are two main methods of wiring a lighting installation.

- Each ceiling rose or junction box is fed from the previous one in the form of a chain.
- The main feed is brought into a central junction box and each point is fed from it (like the spokes of a wheel).

There are of course variations involving combinations of these two methods depending on the shape and size of the installation.

Socket outlet circuits

Radial circuits

Radial circuits are arranged in the same way as item 1, above, in lighting layouts, in that each socket outlet is supplied via the previous one (Figure1.71).

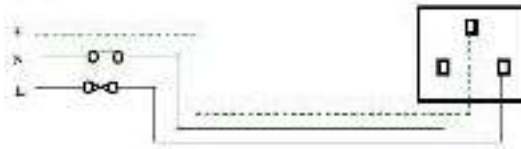

Figure 1.69 Single Socket outlets

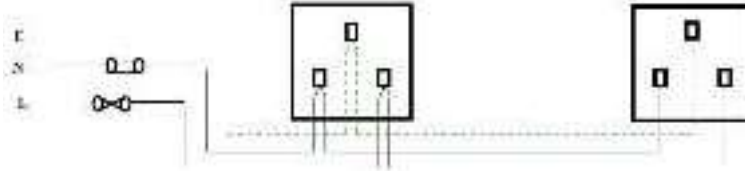

Figure 1.70 Two socket outlet

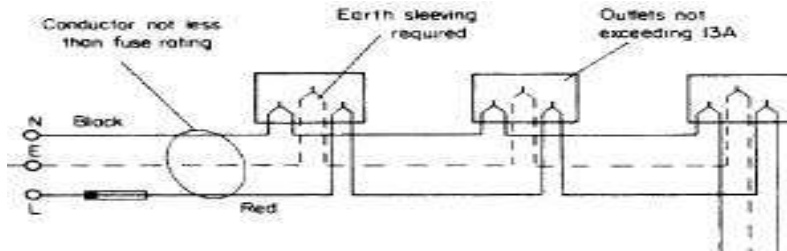

Figure 1.71 Radial circuits (PVC insulated)

Points to note

- The number of socket outlets, complying with BS 1363, is unlimited for a floor area of up to 50m² if the circuit protection is a 20A cartridge fuse or circuit breaker, the cable/wire copper of 2.5mm² PVC insulated.
- The number of socket outlets is unlimited for a floor area up to 20m² with any type of circuit protection of 16 A using 2.5mm² PVC copper cable/wire.
- The total number of fused spurs is unlimited.

Ring final circuits

These circuits are the same as radial circuits except that the final socket outlet is wired back to the supply position. In effect any outlet is supplied from two directions.

Points to note

- Every twin-socket outlet counts as two single-socket outlets.
- The number of non-fused spurs must not exceed the total number of points on the ring. The fuse rating of a fused spur box must not exceed 16A and the current rating of all points supplied by the fused spur must not exceed 16A.
- Non-fused spurs must supply *no more* than one single or one double socket or one stationary appliance.

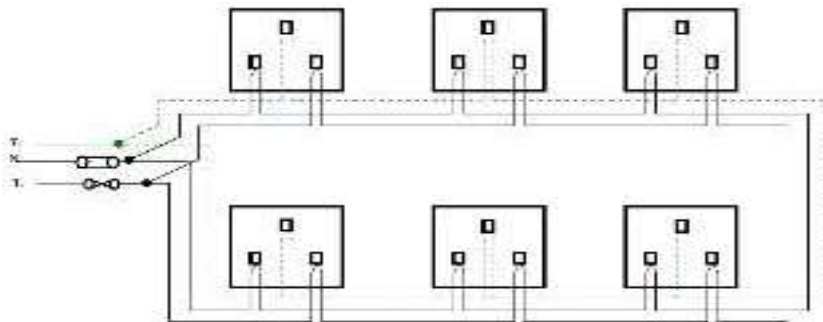

Figure 1.72 Ring final circuit

- d. For domestic premises of area less than 100m², a ring circuit may serve an unlimited number of points.
- e. Cable sizes for ring circuits using copper conductors are: 2.5mm² PVC insulated.

Note: When using some 2.5mm² flat twin with earth cable, a 1.0mm² circuit protective conductor (CPC) is too small to comply with the regulations unless a circuit breaker.

Fixing Positions of Switches and Sockets

Part M of the Building Regulations requires switches and socket outlets in dwellings to be installed so that all persons, including those whose reach is limited, can easily reach them. The recommendation is that they should be installed in habitable rooms at a height of between 450 mm for socket outlets and 1200-1500mm for switches, push button, and fan regulator switch, kitchen power sockets, from the finished floor level. This is shown in Figure1.73

The guidance given applies to all new dwellings but not to re-wires. However, these recommendations will undoubtedly ‘influence’ decisions taken when re-wiring dwellings.

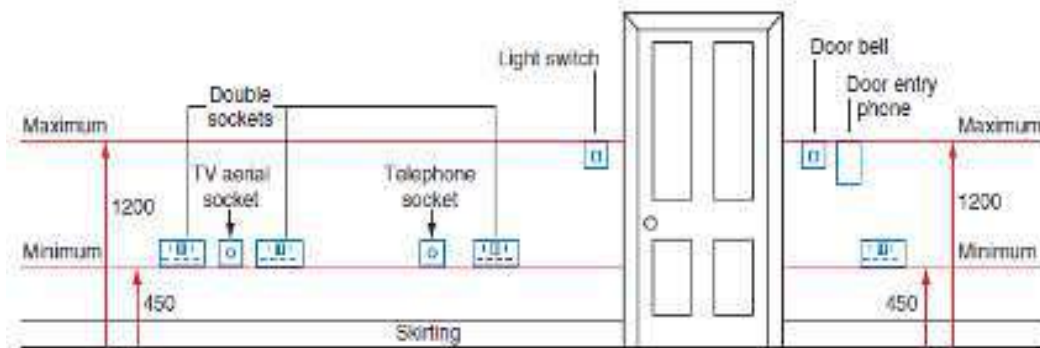

Figure1.73 Fixing positions of switches and socket outlets

Plastic Plugs

A plastic plug is made of a hollow plastic tube split up to half its length to allow for expansion. Each size of plastic plug is color coded to match a wood screw size.

A hole is drilled into the masonry, using a masonry drill of the same diameter and to the same length as the plastic plug (see Figure1.74). The plastic plug is inserted into the hole and tapped home until it is level with the surface of the masonry. Finally the fixing screw is driven into the plastic plug until it becomes tight and the fixture is secure.

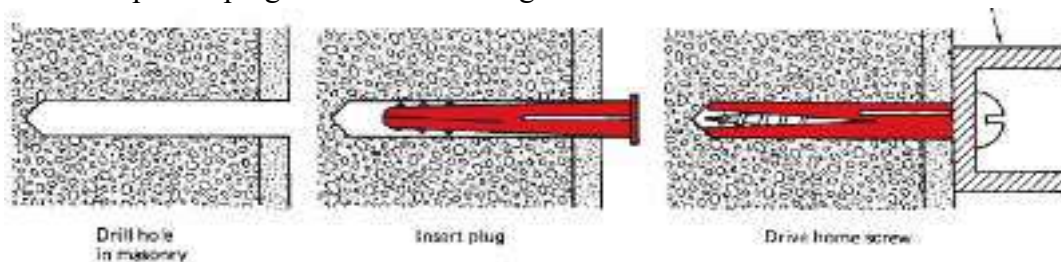

Figure1.74 fixing plastic Plugs

1.5.8 Earthing

Earthing is a connection system between the metallic parts of an electrical wiring system and the general mass of the earth. This will provide an easy path with a low impedance or resistance to earth to enable the protection system to operate effectively. It will thus ensure safety to human beings/consumers from the dangers of electric shocks if earth leakage currents are present. In general, an electrical installation is earthed because of: -

- Safety reasons.
- Protection system requirements.
- Need to limit over voltages.
- Need to provide a path for electrical discharge.
- Legal requirements.

1.5.9 Classification of Earthing

Generally, earthing can be divided into 2 parts, namely: -
System Earthing

- To isolate the system under fault conditions;
- To limit the potential difference between conductors which are not insulated in an area;
- To limit the occurrence of over voltages under various conditions.

Types and Functions of Earthing Accessories

Earthing Electrode: Copper jacketed steel core rods are used as electrodes for domestic wiring.

Equipotential Bonding: This is the conductor which is connected between the consumer earthing point and the exposed metallic part. The minimum cable size for this purpose is 10 mm²

Protection Conductor: This is the conductor which connects the consumer earthing point with other parts of the installation which needs earthing. Its size is as follows:-

- Same size as the phase cable up to a size of 16mm²,
- 16 mm², if the phase cable size is between 16 mm², and 35mm²
- Half the size of the phase cable if the size of the phase cable exceeds 35 mm²

Earthing Arrangements Using a TT System

- The **first** alphabet indicates the earthing arrangements from the *supply side*.
- The **second** alphabet indicates the earthing arrangement in the *consumer's installation*.
- ✓ T – first: Indicates that the supply system has its own earthing arrangements
- ✓ T – Second: Indicates that all metallic frames of the electrical appliances, etc. are connected directly to earth.

The earthing arrangement using a TT system is as shown in Figure 1.75

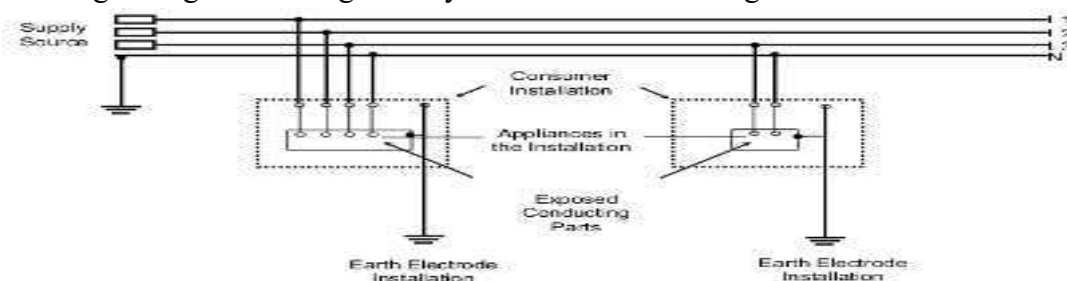

Figure 1.75 TT System Earthing

1.6 prevention potential hazards

1.6.1 Electrical Hazards

Page 53 of 102	Ministry of Labor and Skills Author/Copyright	Apply Basic Electrical Practices	Version -1 August 2022
----------------	--	----------------------------------	---------------------------

Basically, electrical hazards can be categorized into three types.

- The first and most commonly recognized hazard is **electrical shock**.
- The second type of hazard is **electrical burns** and
- The third is the **effects of blasts** which include pressure impact, flying particles from vaporized conductors and first breath considerations

a) Terms and Definition used in Types of Health Hazards

Burns:-Most common shock-related injury results in electrical, arc flash, or thermal contact injuries.

Electrocution:- Means to kill with electricity and occurs when a person is exposed to a lethal amount of electrical energy.

Shock:- A reflex response to the passage of electric current through the human body and results when electric current enters the body at one point and leaves through another.

Arc Flash or Arc Blast:- Sudden release of electrical energy through the air that gives off thermal radiation (heat) and bright, intense light that can cause burns. Temperatures have been recorded as high as 35,000 °F.

Fire:- Fixed wiring, such as faulty electrical outlets and old wiring, is the most common cause. Problems with extension and appliance cords, plugs, receptacles, and switches are also responsible.

Explosions: - Can occur when electricity ignites an explosive mixture of materials in the air.

b) Safety Requirements

Safety requirements for electrical wiring works have to be followed to eliminate any accidents which can result in physical damage or loss of life or property. Failure to meet the safety regulations may result in workers, consumers or the public being inflicted with electrical shocks.

In addition to this, safety steps will also encourage workers or electricity consumers who are disciplined and who always give importance to safety.

1.6.2 Safety Steps for Electrical Hazards

Safety requirements have to be followed whenever electrical works are undertaken in a residential building.

I. Personal Safety

- a) Use suitable personal protection equipment as needed such as safety shoes, gloves, safety helmet, etc. when at the work place.
- b) Use safety clothing suitable for the work to be undertaken.
- c) Do not wear jewelry or decorative items such as rings, watches, chains, etc. while carrying out electrical works.

II. Safety at the Work Place

- a. Acquire knowledge about the dangers of electrical works that is to be undertaken and how to deal with those dangers.
- b. Always adhere to the safety regulations which have been set for the work place.
- c. Ensure that the electricity supply is switched off before carrying out the works.

- d. Acquire the needed knowledge and practice a cautious and calm attitude while working, ensure cleanliness in and around the workplace, do not smoke and always coordinate work with fellow workers.
- e. While working at elevated places, the worker should always use suitable equipment such as wooden or aluminum ladders, iron scaffoldings or platforms, safety belts or other equipment needed to ensure that the work can be undertaken safely.
- f. Use electrical equipment which is operational and safe to be used and ensure that the supply for it is being supplied through a residual current device (RCD) with a sensitivity of 30mA.
- g. Ensure that exposed temporary supply electrical cables have mechanical protection.
- h. If inflammable or corrosive material is present, necessary safety steps have to be undertaken as required by the relevant safety regulations.

1.6.3 Dangers of Electrical Shocks

i. Electrical Shock

Electric shock occurs when the human body becomes part of a path through which electrons can flow (of an electrical circuit). There are many ways that a person's body can become part of an electrical circuit and get shocked. Shocks can happen in three ways.

- A person may come in contact with both conductors in a circuit.
- A person may provide a path between an ungrounded conductor (live wire) and the ground.
- A person may provide a path between the ground and a conducting material that is in contact with an ungrounded conductor.

The level or intensity of the shock will depend upon many factors such as *age, fitness* and the *circumstances* in which the *shock is received*.

Electrical shocks can occur due to direct or indirect contact.

- a. **Direct Contact:** Direct contact occurs when the worker or consumer receives an electrical shock on touching directly a live conductor or cable.
- b. **Indirect Contact:** Here the electric shock occurs due to contact with a part which is connected to the electrical installation and not to a direct contact with a live cable or conductor, possibly due to damages in the appliance or insulation, resulting in leakages of current.

ii. Why Electric Shocks Occur

a) Unsafe Work Method or Action

- **Undertaking Electrical Work Without Disconnecting the Supply**

Maintenance or circuit testing work done without disconnecting the supply will have a high possibility of electrical shocks occurring.

- **Not Following Safe Work Procedures**

To eliminate the occurrence of electrical shocks, each worker has to always follow safe work procedures which are set by regulations and standards.

b) Defects in the Electrical System

- **Leakage Current**

Leakage currents or earth leakage currents can result in the metallic frames becoming live and energized. This can give rise to the danger of electrical shock to the worker, consumer or the public if they hold or come into contact with the metallic frame.

- **Exposed Conductor or Disconnected Cable**

Exposed conductors or cables which are broken and are alive (energized) can result in electrical shock when touched. The supply source must be immediately isolated or switched off and a report must be made to the responsible entity. The effects of electric shock on the human body depend on several factors. The major factors are:

- a) Current and Voltage
- b) Resistance
- c) Path through body
- d) Duration of shock

Electrocution Dangers

The most common electrocution dangers in the manufacturing industry are:

- Contacting overhead power lines.
- Contacting energized sources, such as live parts, damaged or bare wires, defective equipment, or tools.
- Using extension or flexible cords improperly.

a) Overhead Power Lines

- Overhead and buried power lines are especially dangerous to workers because they carry extremely high voltage ranging from 120 to 750,000 volts. The most reliable way to know a power line's voltage is to ask the utility company that owns the line.

a) Energized Sources

- Electrical shock and burns are the major dangers from contact with energized sources. Electrical shock happens when an individual comes in contact with;
 - ✓ both wires of an electrical circuit
 - ✓ one wire of an energized circuit and the ground, or
 - ✓ a metallic part that is energized by contact with an electrical conductor.

b) Improper Use of Cords

- Flexible extension cords are more susceptible to damage than fixed wiring because they are exposed and unsecured. Workers create hazards when cords, cord connectors, receptacles, and cord- and plug-connected equipment are not used and maintained properly.

1.2.4 Safety Signs

Safety signs are displayed in the working environment to inform workers of the rules and regulations especially relevant to inform and give warning of possible danger and **must be obeyed**. There are **four types** of safety signs:

- a. Warning signs
- b. Advisory signs
- c. Mandatory signs
- d. Prohibition signs particular section of the workplace

A. Warning Signs (these give safety information)

These are triangular yellow signs with a black border and symbol as shown in

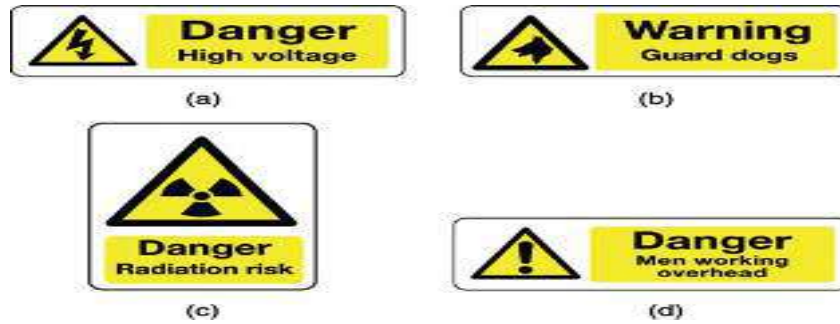

Figure 1.76 Warning Signs

B. Advisory Signs (these also give safety information)

Advisory or safe condition signs are square or rectangular green signs with a white symbol as shown in Figure 1.77 They give information about safety provision

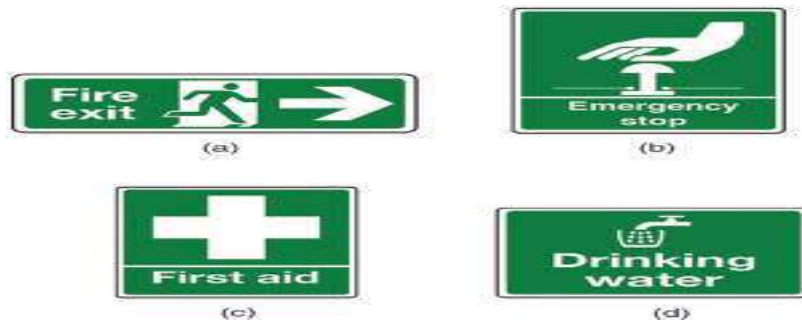

Figure 1.77 Advisory or Safe Condition Signs

C. Mandatory Signs (these are ‘MUST DO’ signs)

These are circular blue signs with a white symbol as shown in Figure 1.78 they give instructions which **must be obeyed**.



Figure 1.78 Mandatory Signs

D. Prohibition Signs (these are ‘MUST NOT DO’ signs)

These are circular white signs with a red border and Red Cross bar as shown in Figure 1.79 They indicate an activity which **must not** be carried out.

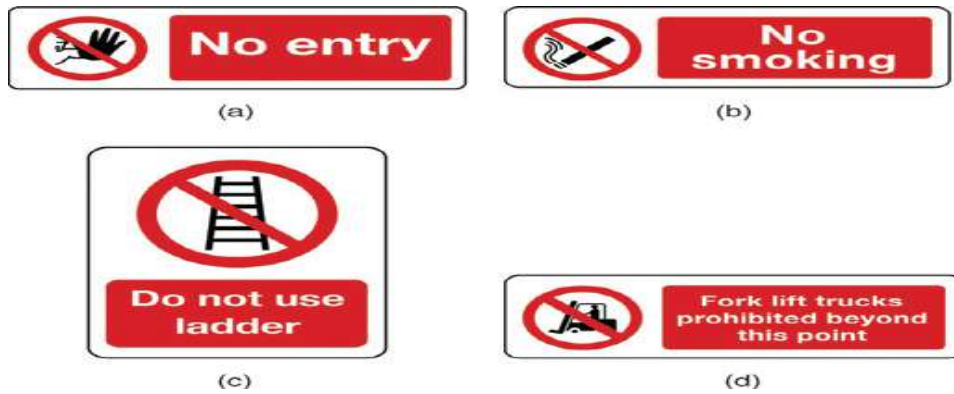

Figure 1.79 Prohibition Signs

In the event of a fire you should:

- raise the alarm
- turn off machinery, gas and electricity supplies in the area of the fire
- close doors and windows but without locking or bolting them
- remove combustible material away from the path of the fire if this can be done safely
- attack small fires with the correct extinguisher

Fire Prevention

Fire Extinguisher

A suitable, functioning fire extinguisher to control fires has to be made available at the work place at all times.

Fires are divided into Four Classes or Categories

- I. Class A are wood, paper and textile fires
- II. Class B are liquid fires such as paint, petrol and oil
- III. Class C are fires involving gas or spilled liquefied gas
- IV. Class D are very special types of fire involving burning metal

6.4 First Aid and Basic Pulmonary Resuscitation

i. First Aid

First aid is the initial assistance given to a person who has met with an accident, is sick or is injured to prevent the condition of the victim from becoming more serious while awaiting the arrival of the paramedics (ambulance) or before being brought to the hospital.

ii. Pulmonary Resuscitation

Pulmonary resuscitation has to be undertaken to assist the victim who has breathing difficulties as a result of being drowned, receiving an electrical shock, etc.. Pulmonary resuscitation has to be carried out in accordance to the correct method as stated in the first aid manuals issued by accredited first aid bodies.

iii. First Aid Box

A first aid box has to be provided by the building owner, construction site supervisor or brought personally by the worker under the supervision of the responsible person.

Hazard Prevention and Control

After hazards are identified, how can they be prevented and controlled? Continually review the farmstead, shop areas and work practices to control or prevent workplace hazards. Some ways to prevent and control hazards are:

- Regularly and thoroughly maintain equipment
- Ensure that hazard correction procedures are in place

- Ensure that everyone knows how to use and maintain personal protective equipment
- Make sure that everyone understands and follows safe work procedures after detection, all current and potential hazards must be prevented, corrected or controlled.

Systems used to prevent and control hazards include:

- ♣ Engineering Controls
- ♣ Administrative Controls
- ♣ Personal Protective Equipment (PPE)
- ♣ Systems to Track Hazard Correction
- ♣ Preventive Maintenance Systems
- ♣ Emergency Preparation



Figure 1.80 Hazardous socket

3. How many hazards/violations are there in this picture? _____.

1.7 Prepare work area

1.7.1 Consider Before Starting an Electrical Project

- 1) Know Your Own Grid.
- 2) Consider Labeling Everything.
- 3) Understand the Basic Electrical Codes.
- 4) Read the Installation Instructions Thoroughly.
- 5) Always Turn Off the Power.
- 6) Think About the Condition of the Materials.
- 7) Work through Your Lighting Needs.

➤ The important to be equipped with the basic skills in doing electrical works

What are the things you need to consider in preparing an electrical plan?

Power lines with details such as **size, voltage, rating, and capacity**. Power transformers and also their winding connections. **The main switches, tiebreaker, and fused switches**. Other essential equipment such as solar panels, batteries, generators, air conditioning, and so on

➤ the most important rule of electrical safety is

Page 59 of 102	Ministry of Labor and Skills Author/Copyright	Apply Basic Electrical Practices	Version -1 August 2022
----------------	--	----------------------------------	---------------------------

For added safety, use a lock to prevent anyone from turning the power back on. Conclusion: Thus, the most important rule of electrical safety is to **de-energize the electrical circuit before working on it**

1.8 Resolve co-ordination requirements

1.8.1 Establish effective communication

Each general contractor establishes and implements a procedure to ensure the exchange of information about hazards present on site and the hazard control measures in place. Thus, all workers on the site are aware of worksite hazards, and the methods and procedures needed to control exposures to them.

1.8.2 Establish effective coordination

General contractors, contractors, subcontractors, and staffing agencies coordinate on work planning, scheduling, and resolving program differences to identify and work out any concerns or conflicts that could impact safety or health.

- Include in contracts and bid documents any safety-related specifications and pre-qualifications and ensure that contractors, subcontractors, and staffing agencies selected for the work meet those requirements.
- Identify issues that may arise during on-site work and include procedures to be used by the general contractor, contractors, subcontractors, and staffing agencies for resolving any conflicts before work starts. This may be accomplished through pre-construction meetings.
- Ensure that joint-employed workers are adequately trained and equipped before arriving on the worksite.
- Harmonize their safety and health policies and procedures to resolve important differences, so that all workers at the site have the same protection and receive consistent safety information (i.e., conduct site-specific training).
- Work together to deal with unexpected staffing needs by ensuring that enough trained and equipped workers are available or that adequate lead time is provided to train and equip workers.
- Make sure that managers with decision making authority are available and prepared to deal with day-to-day coordination issues.

Need for effective coordination in Workplace

Coordination minimizes the conflicts, rivalries are ended, wastages, delays, indifferences and other organizational problems.

It ensures smooth function of the organization. Hence, with the help of coordination an organization can fulfill its objectives promptly.

Page 60 of 102	Ministry of Labor and Skills Author/Copyright	Apply Basic Electrical Practices	Version -1 August 2022
----------------	--	----------------------------------	---------------------------

Self check-1

Test-I multiple question

1. Which one of the following is Electrical Safety?
 - a. Plan every job and think about what could go wrong.
 - b. Use the right tools, procedures for the job.
 - c. Isolate equipment from energy sources.
 - d. all
2. ----- is that might be needed for protection against electric shock.
 - a. Personal Protective Equipment
 - b. Equipment
 - c. First aid
 - d. A and b
3. Pliers, cutters, a knife and a range of screwdrivers are the tools required in the electro-technical industry for:

a) erecting conduit	c) stripping and connecting conductors
b) Assembling tray	d) terminating an MI cable
4. All of the following instruments are electrical quantity measuring instruments except:

a) Ammeter	b) voltmeter	c) ohmmeter	D. Measuring Tape
------------	--------------	-------------	-------------------
5. The angle of a ladder to the building upon which it is resting should be in the proportions of:

a) 1 up to 4 out	c) 4 up to 1 out
b) 4 up to 75 out	d) 75 up to 4 out
6. A fish tape or fishing tools is used in electrical wiring for:

a) Pulling the wires through the conduit	c) splicing wire
b) Electrical conductor	d) wire connection
7. The angle which a correctly erected ladder should make with level ground is:

a) 41°	c) 57°
-----------------	-----------------

Operation sheet - 1 Draw wiring diagram

- **Operation title: Basic Electrical Practices**
- **Purpose:** According to the given drawing diagram, the next switch is to light a bulb

Instruction: According to the given diagram, using the required materials and order, you will turn on the electricity. The time given to you is two hours.

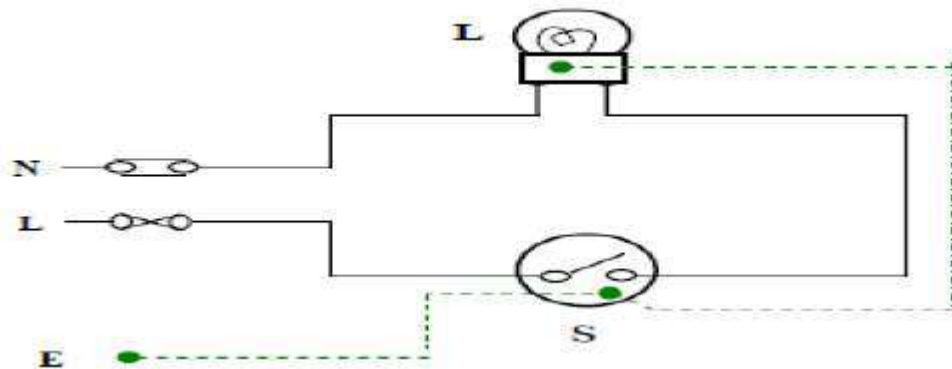

Figure1.81 circuit diagram

- **Tools and requirement:**

- Screw Drivers
- Pliers
- **Wire 2.5mm**
- **Conduct**
- **Scotch**
- **Switch**
- Lamp
- Pendant holder
- Screw
- voltage indicator

Steps in doing the task

- use safety first
- Read the wiring diagram

- With the help of plier and stripper share the ends of wire of required length
- Measure and mark out the location of components
- Fix junction box and conduit
- Install wiring in the conduit
- Connect the wiring system

Quality Criteria: It is confirmed by seeing that the electric line is properly laid without mess

Precautions: Before you test the light, remove any hazards

Lap Test- 1

- Perform safety ruler
- Read the diagram correctly
- Measure the location of components
- Install wiring in the conduit
- Perform the Connecting wiring system

Unit Two: Conduct Minor Handling and Maintenance

This unit to provide you the necessary information regarding the following content coverage and topics:

- essential of isolations
- minor maintenance

- minor adjustments
- Reporting fault

This guide will also assist you to attain the learning outcomes stated in the cover page. Specifically, upon completion of this learning guide, you will be able to:

- Conform required isolations
- Conduct minor maintenance
- Undertake minor adjustments
- Reporting fault

2.1 Essential of Isolations

2.1.2 Energy Isolation

Energy sources will be isolated whenever workers are required to work in and around energized equipment regardless of the source of energy. The following requirements apply and will be overseen by IFS or the nominated representative:

- Isolation will always be undertaken at the energy source and will not rely on control circuitry such as stop switches , interlocks, emergency stops or lanyards ;
- Positive isolation will be used i.e. the energy source has been isolated, tested and the isolation is proved to have worked;
- Wherever practicable, isolation will be secured by the use of a personal locking device which requires a key for removal;
- The equipment will also be tagged at the control panel to indicate it is isolated;
- Prior to work commencing the equipment will be tested to verify it has been isolated;

If a personal locking device cannot be used, a personal danger tag will be used instead by each worker involved with the job.

The danger tag indicates that the person identified on the tag is involved in the work related to the item of equipment and is at risk of personal harm if the equipment is re-energized while the danger tag is in place;

- A personal danger tag will only be removed from the isolation point by the person identified on the tag who placed it on the isolator;
- De-isolation and re-energizing of equipment will only occur when all personal locks or danger tags have been removed;
- If for any reason the person identified on a personal danger tag is not available to remove it when the work is completed, it will only be removed by an authorized person at the site after following these actions:
 - ✓ Inspecting the area;
 - ✓ Making personal contact with the tag owner, in person or by phone; or
 - ✓ Seeking reliable information from a third party that the person has left the area.

An out of service tag is used to indicate an item of equipment is defective and that the equipment will not be used until cleared for safe operation by an authorized and competent person. The following requirements apply to out of service tags:

- An out of service tag will be placed on all defective equipment as soon as the defect has been recognized;

- The item of equipment will not be used while the out of service tag is in place. The tag will remain in place at all times while the equipment is isolated, defective or being worked on;
- The tag will indicate the date and time that it has been applied and the name of the person who placed the tag;
- An out of service tag will only be removed by a competent person once the defect has been corrected.

2.1.3 Isolation:

a function intended to cut off for reasons of safety the supply from all, or a discrete section, of the installation by separating the installation or section from ~very source of electrical energy.

- **Isolator:** a mechanical switching device which provides the function of isolation.
- Every year, people working on construction sites suffer electric shock and burn injuries some of which, tragically, are fatal. Members should be aware that some of these accidents are a direct consequence of electrical contractors not implementing safe isolation procedures. An example of one such fatal incident that occurred recently in the work site is provided in the box below.



Figure 2.1 Wrong installation of socket out let from distribution board

An electrician working on a new-build construction project installed the 3-phase and neutral distribution board shown in the photograph.

S/He energized the supply to the distribution board before the circuits connected to it were complete, to provide a supply to a socket outlet.

S/He was connecting the supply cables to a wall-mounted timer unit, with the phase conductor connected to the circuit breaker at the top left hand side of the bus bar assembly. The circuit breaker had not been securely isolated and was ON as s/he stripped the insulation from the end of the cable. S/He touched the live copper conductor of the cable and was electrocuted.

The distribution board was manufactured to a high standard of safety. However, if s/he needed to energize the board before it was complete, s/he should first have replaced the cover and switched off and locked the circuit breakers supplying unfinished or incomplete circuits. S/He should also have ensured that circuits were not connected into circuit breakers until after they were complete and had been tested

This brochure has been produced in conjunction with the Health and Safety Executive (HSE), and its purpose is to provide practical guidance on low voltage safe isolation procedures

during construction projects and is aimed at preventing these types of incidents, and protecting employees and other workers against serious or fatal electrical injuries. The guidance is particularly relevant to circumstances where work is being carried out in the presence of other trades, and to sites where more than one electrician is employed, although the principles will apply generally.

2.1.4 Safe Isolation Practice

For work on LV electrical equipment or circuits, it is important to ensure that the correct point of isolation is identified, an appropriate means of isolation is used and the supply cannot inadvertently be reinstated while the work is in progress. Caution notices should also be applied at the point(s) of isolation, and the conductors must be proved to be dead at the point of work before they are touched.

A fundamental principle is that the point of isolation should be under the control of the person who is carrying out the work on the isolated conductors.

The means of isolation can be an adjacent local isolation device such as a plug and socket, switch-disconnection, circuit breaker, fuse etc, as appropriate, which is under the direct control of the competent person carrying out the work. These devices can be used without further precautions provided there is no foreseeable risk that the supply could be reinstated by others.

When there is no such local means of isolation or there is a risk of reinstatement of the supply as above, the circuit or equipment to be worked on should be securely isolated by one of the following methods.

A. Isolation using a main switch or distribution board (DB) switch-disconnected

Isolation of equipment or circuits using the main switch or DB switch-disconnected is the preferred method. The point of isolation should be locked off using a unique key or combination retained by the person carrying out the work. In the case of multiple isolations on a DB, a multi-lock hasp can be used to prevent access to a main isolator until such time that all persons working on a system have completed their work and removed their padlocks from the hasp.

If locking-off facilities are not provided on the relevant switch then a locked DB door or locked switch-room door is acceptable provided the key or combination is unique, and is retained by the person doing the work. Again, multi-lock hasps can be used to control multiple isolations, although a key box or similar system may be needed to retain and control access to the main door key



Figure 2.2 Main Switch/MCB Isolation, Lock and Tag

Where it is intended that more than one person will be working on circuits supplied from a DB, (i.e. multiple isolations) and a multi-lock hasp cannot be used to secure the main point of isolation, individual isolation of each circuit by one or more of the methods shown below is recommended, to prevent inadvertent reinstatement of the supply. The principle is that each person carrying out such work should have control of their own point(s) of isolation and not rely on others to prevent inadvertent energize.



Figure 2.3 Multi-Lock Hasp

B. Isolation of individual circuits

Where it is not practical to isolate a distribution board, individual circuits supplied from it can be isolated by one of the methods described below, depending on the type of protective device used. However, bear in mind the overriding advice to avoid energize any outgoing electrical distribution services, preferably until the distribution switchgear and all connected circuits are complete and have been inspected and the relevant tests carried out.

If any items required to carry out the procedures recommended below are not manufactured for the DB in question or cannot be obtained through retail/trade outlets, it is acceptable to disconnect the circuit from the DB as long as the disconnected tails are made safe by being coiled or insulated. Suitable labeling of the disconnected conductors is important to prevent the supply being re-instated, particularly if other electricians are present.

It should be remembered that work carried out inside a live DB is regarded as live working when there is access to exposed live conductors. In this case the appropriate precautions should be taken as described in HSG85 with respect to Regulation 14 of the Electricity at Work Regulations.

i. Isolation of individual circuits protected by circuit breakers

Where circuit breakers are used the relevant device should be locked-off using an appropriate locking off clip with a padlock which can only be opened by a unique key or combination. The key or combination should be retained by the person carrying out the work.



Figure 2.4 Circuit Breaker locking off clip with a padlock

Note

Page 68 of 102	Ministry of Labor and Skills Author/Copyright	Apply Basic Electrical Practices	Version -1 August 2022
----------------	--	----------------------------------	---------------------------

Some DBs are manufactured with ‘Slider Switches’ to disconnect the circuit from the live side of the circuit breaker. These devices should not be relied upon as the only means of isolation for circuits as the wrong switch could easily be operated on completion of the work.

ii. Isolation of individual circuits protected by fuses

Where fuses are used, the simple removal of the fuse is an acceptable means of disconnection. Where removal of the fuse exposes live terminals that can be touched, the incoming supply to the fuse will need to be isolated. To prevent the fuse being replaced by others, the fuse should be retained by the person carrying out the work, and a lockable fuse insert with a padlock should be fitted as above. A caution notice should also be used to deter inadvertent replacement of a spare fuse. In addition, it is recommended that the enclosure is locked to prevent access as stated above under ‘Isolation using a main switch or distribution board (DB) switch-disconnection’. Note

In TT systems, the incoming neutral conductor cannot reliably be regarded as being at earth potential. This means that for TT supplies, a multi-pole switching device which disconnects the phase and neutral conductors must be used as the means of isolation. For similar reasons, in TT systems all poles of the supply must be disconnected. Single pole isolation in these circumstances is not acceptable

iii. Electrical Permits-to-Work

An electrical permit-to-work must be used for work on HV systems that have been made dead, and can be useful in certain situations for LV work. These permits are primarily a statement that a circuit or item of equipment is isolated and safe to work on. They must not be used for live working as this can cause confusion. Details on the use of these permits, including an example form, are given in HSG85.

Caution Notes

In all instances where there is a foreseeable risk that the supply could be reinstated as above, an appropriate “caution” notice should be placed at the point of isolation. For DBs with ‘multiple isolations’ a single suitably worded notice on each DB, such as the example shown below, would suffice:



Figure 2.5 Example of Warning Notice

CAUTION: *This Distribution Board Has A Number Of Circuits That Are Separately Isolated. Care Should Be Taken When Reinstating The Supply To An Individual Circuit That It Has Been Correctly Identified.*

The test instrument should be proved to be working on a known live source or proprietary proving unit before and after use. All phases of the supply and the neutral should be tested and proved dead.

2.1.5 Safe Electrical Isolation and Lock Off

As an electrician working on electrical equipment you must always make sure that the equipment or circuit is electrically dead before commencing work to avoid receiving an electric shock and because:

- the Electricity at Work Regulations 1989 tell us that before work commences on electrical equipment it must be disconnected from the source of supply and that disconnection must be secure. A small padlock or the removal of the fuse or MCB will ensure the security of the disconnection
- the IEE Regulations (130-06-01) tell us that every circuit must be provided with a means of isolation
- larger pieces of equipment and electrical machines will often have an isolator switch close by which may be locked off
- to deter anyone from trying to re-connect the supply while work is being carried out, a sign 'Danger Electrician at Work' should be displayed on the isolator or source of the supply in addition to the small padlock
- where a test instrument or voltage indicator such as that shown in used to prove the supply dead, the same device must be tested to prove it is still working by using a 'proving unit' such as that shown in Fig. 2.5
- the test leads and probes of the test instrument must comply with the Health & Safety Executive Guidance Note 38 giving adequate protection to the user as shown in figure

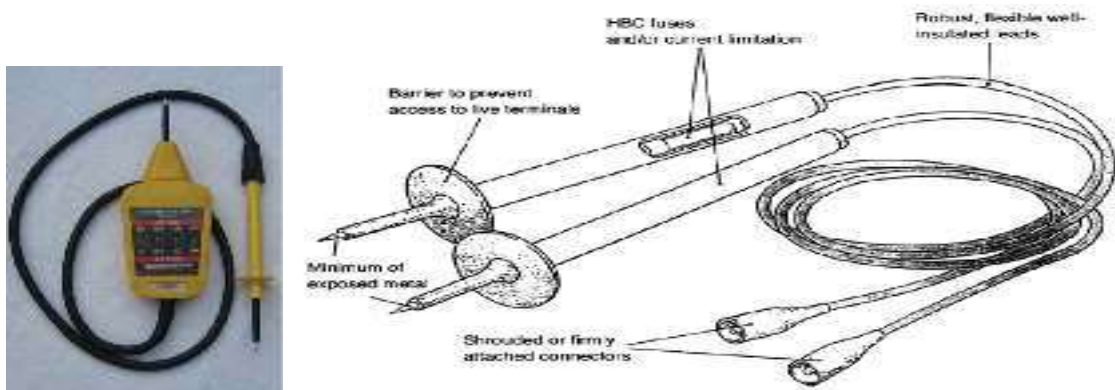

Figure 2.1.6 Typical voltage indicator

2.6 Safe isolation procedures & proper equipment save lives

There is a number of locking off kits available on the market; however a basic kit should include the following:

- Selection of MCB & breaker locks
- Padlock with a unique key or combination
- Hasp for when more than one person is working on a system
- Lock out tags & warning labels



Figure 2.7 basic kit in Isolation

2.1.7 Steps to Safe Isolation

Step 1: Check with the duty holder/authorized person that it is acceptable to isolate the circuit/equipment.

Step 2: Ensure that there is a ‘Permit to Work’ in place.

Step 3: Identify the type of supply system

- ❖ TN-S – linked main switch
- ❖ TN-C-S – linked main switch
- ❖ TT – all pole Isolation – All circuits and equipment.

Step 4: Locate and identify the circuit/equipment to be isolated including any alternative sources

Step 5: Select an approved voltage indicator device

Step 6: Verify the circuit/equipment is functional.

- If the circuit is not operational, dead testing may be required to verify the circuit.

Step 7: Identify suitable means of isolation.

Step 8: Isolate circuit / equipment by:

- Switching off
- Double-Pole/ three-phase Isolator
- Circuit-Breakers
- Withdrawing fuse.

Step 9: Fit appropriate lock off device and locks.

- Person carrying out works to retain key.
- Fit warning label for isolation and
- identified work Issue permit to Work

Step 10: Verify the circuit/equipment is isolated. Use the approved voltage indicator device to verify circuit is dead. Test between all conductors-Line-Line, Line-Neutral, Line-Earth, and Neutral-Earth

- 3 Phase = 10 tests
- 1 Phase = 3 tests

Step 11: Re-check the approved voltage indicator device is still functional

- On the same proving system as Step 5.

Step 12: Circuit/equipment should be safe to carry out the work.

- Always remain vigilant and recheck

Figure 1.14 steps of safe isolation procedures

2.2 Minor Maintenance

Related to Minor repairs and maintenance

A .Planned Maintenance :- means any preventative, routine or scheduled maintenance which is performed with regards to the Service, the Network, the Partner’s network or any component thereof, reasonably believed to be necessary in order to increase capacity or to prevent or remedy a defect which may affect the Customer's use of or access to the Services.

B. Operation” shall mean all activities required to operate, maintain, and monitor the effectiveness of the Plan.

C. Erection Maintenance construction, remodeling, repairing means all types of work done on a particular building or work at the site thereof in the construction or development of the project, including without limitation, erecting, construction, remodeling, repairing, altering, painting, and decorating, the transporting of materials and supplies to or from the building or work done by the employees of the Contractor, Subcontractor, or Agent thereof, and the manufacturing or **D. D. D. D. Furnishing of Maintenance work** means the repair of existing facilities when the size, type or extent of such facilities is not thereby changed or increased. While “maintenance” includes painting and decorating and is covered under the law, it does not include work such as routine landscape maintenance or janitorial services.

E. Routine Maintenance means activities to keep an impervious surface as near as possible to its Working condition. This includes ordinary maintenance activities, repairing changes or improvements which do not materially increase..

F. Operation And Maintenance Costs Means for any fiscal year or other period, the reasonable and necessary costs and expenses of operating the common areas of the Project and of managing and repairing and other expenses necessary to maintain and preserve the common areas of the Project in good repair and working order, calculated in accordance with Generally Accepted Accounting Principles, including but not limited to

2.2.1 Basic Maintenance of Electrical Tools And Equipment

To ensure that your electric tools work when you need them, you must take proper care of them. A good routine of maintenance for your tools is one thing that you can do to make sure that the tool you need is working when you need it.

2.2.2 Maintenance

(a) In the design, construction and installation of an electrical installation, consideration must be given to its subsequent maintenance. It should be noted that electrical equipment must not only be so constructed and protected as to be suitable for the conditions under which they are required to operate, but must also be installed to be capable of being maintained, inspected and tested with due regard to safety.

(b) For the purpose of maintenance, it is important to ensure the safety of persons approaching electrical equipment to work on it or attend to it. Guidelines on the provision of adequate and safe means of access and working space are described.

Maintenance Practices Are Very Simple, Easy Habits That You Can Apply Daily.

Page 72 of 102	Ministry of Labor and Skills Author/Copyright	Apply Basic Electrical Practices	Version -1 August 2022
----------------	--	----------------------------------	---------------------------

- Cool Down Heated Tools. Overworking a tool puts a lot of stress on its motor and can cause it to overheat.
- Clean Regularly.
- Lubricate.
- Sharpen Bits and Blades.
- Calibrate.
- Tool Storage.
- Replace Worn Parts.
- Battery Care.

1. Clean out the Dust. To make sure that your electric tools are ready to go when you are, keep them clean and free of dust. Spend some time to clean out the dust every once in a while on your tools while they are inactive in storage.



Figure 2.8 Clean out Look for tear/cut insulator

2. Check the Cords. Look for tear/cut insulator on the power cords on your electric tools.

This will ensure that your electric tool can get the power that it needs to function without an accident.



Figure 2.9 Look for tear/cut insulator

3. Use the right tool correctly. Use tools correctly and for their intended purposes. Follow the safety directions and operating procedures recommended by the manufacturer.

When working on a circuit, use approved tools with insulated handles.



Figure 2.10 shows Use correctly machine operation

4. Protect your Tools. Keep tools and cords away from heat, oil, and sharp objects. These hazards can damage insulation. If a tool or cord heats up, stop using it. Report the condition to a supervisor or instructor immediately.



Figure 2.11 shows proper tools position

5. Use double-insulated tools - Portable electrical tools are classified by the number of insulation barriers between the electrical conductors in the tool and the worker.



Figure 2.12 shows right tool for right work

6. Storing Your Tools- Keep your electric tools stored in their original cases and containers. This will keep them free of dust and dirt while they are not being used.



Figure 2.13 shows how to keep the electric tools

How-To Replace A Fluorescent Tube Light

Here's how to replace a fluorescent tube light first. Take off the casing by lifting away the end of the fitting which holds it in place lean the casing carefully against the wall and out of the way.

How do I change a starter bulb?

How does a fluorescent starter works in a fluorescent lamp assembly?

Simply put, fluorescent starters are a timed switch. The switch opens and closes until the fluorescent tube 'strikes' and lights-up. If the fluorescent tube does not light, the switch repeats it's open/close cycle and the fluorescent tubes attempts to ignite again.

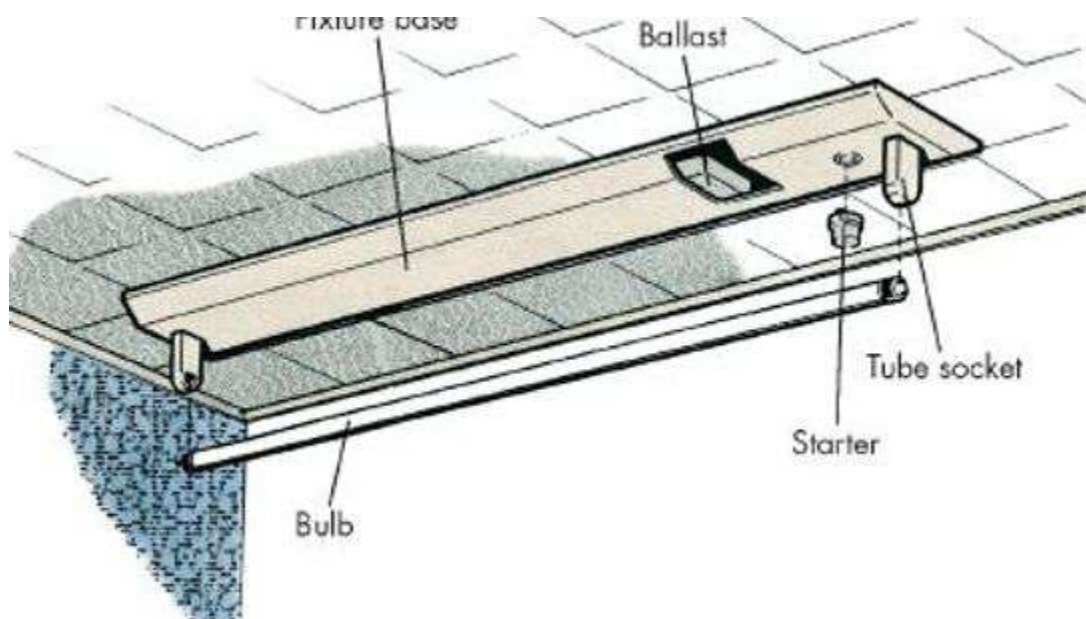

Fig 2.14 fluorescent tube

- **The Use Of Indicator In Switch Board**

As the name implies, indicator lights **reveal the status (ON or OFF) of an electrical apparatus in switchboards.** In more sophisticated systems, the indicating lights may annunciate the cause of the current interruption, such as line-to-ground fault, overload, and overcurrent condition.

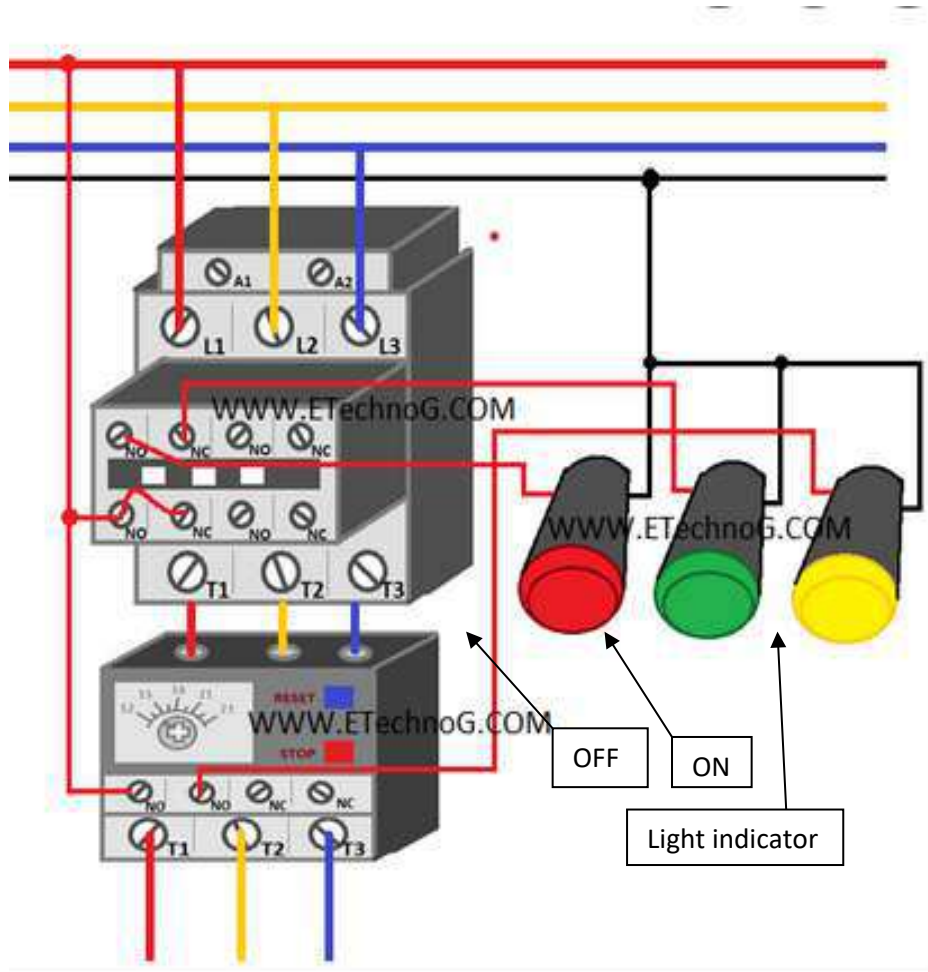

Figure 2.15 switchboards

- **The Functions Of Transformer Oil**

Transformer oil's primary functions are to insulate and cool a transformer. It must therefore have high dielectric strength, thermal conductivity, and chemical stability, and must keep these properties when held at high temperatures for extended periods



Figure 2.16 transformer and with the oil

- **The procedure of oil testing of transformer? Breakdown voltage testing procedure**

The transformer oil is filled in the vessel of the testing device.

- A test voltage is applied to the electrodes and is continuously increased up to the breakdown voltage with a constant, standard-compliant slew rate of e.g. 2 kV/s

c. Batteries inspection

What should batteries be inspected for

Before a performance test can be conducted, it is necessary to inspect the battery for **visual defects and adjustments**. Make sure the battery is the proper size and type for the vehicle application.

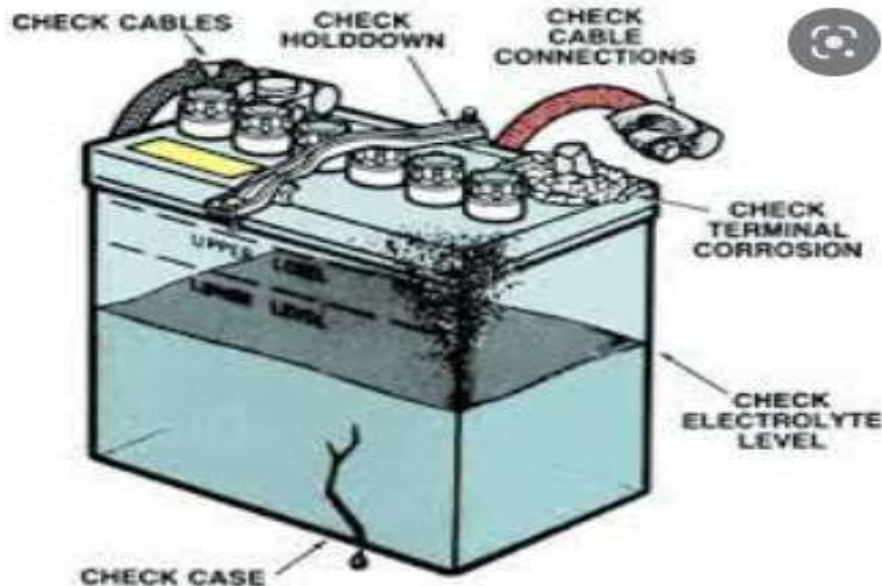

Figure 2.17 Battery parts

d. Battery maintenance

Batteries should be kept clean and free of dirt and corrosion at all times. Batteries should always be watered after charging unless plates are exposed before charging. If exposed, plates should be covered by approximately 1/8" of electrolyte (add distilled water only). Check electrolyte level after charge

There are some tips to keep your equipment in tip-top shape.

1. Clean or replace consumables.
2. Inspect Drive Rolls and Check Tension. ...
3. Keep Your Machine Clean. ...
4. Clean your Liner. ...
5. Inspect Gas Hoses and Fittings. ...
6. Inspect The Cables. ...
7. Inspect The Ground Lead and Clamp. ...
8. Hang It Up! ...

2.3 Minor Adjustments

2.3.1 Adjustment of Electrical installation – Protective devices

Socket outlets, installed in locations other than those referenced in 9.2, and intended to be used for the connection of electrical equipment that may represent an increased risk of

Page 77 of 102	Ministry of Labor and Skills Author/Copyright	Apply Basic Electrical Practices	Version -1 August 2022
----------------	--	----------------------------------	---------------------------

electric shock to the user, shall be protected by RCDs.(residual current device) RCD protection may be at circuit or socket level, with the preference being socket level particularly in situations where increased risk exists. This allows for resetting and testing of the RCD without the need to leave the teaching environment. 10mA RCDs or RCBOs are not required for the following: (residual current circuit breaker)

a) GPOs mounted above 1.8m (Group Policy Object)

b) RUPOs specifically installed for the supply of electricity to IT equipment and cleaning equipment that are clearly marked to indicate the restricted purpose of the socket-outlet and that 10mA RCD protection is not provided

c) GPOs in corridors, halls, gymnasiums and similar areas where portable electrical Appliances are not likely to be used by children Electrical products and equipment

The installation of all electrical products and equipment shall be installed to the manufacturer's guidelines to the correct and relevant regulations and Standards, by a licensed and registered electrician or a trainee under the supervision of a registered and licensed electrician, and, where required by regulations, inspected by a licensed and registered electrical inspector.

2.3.2 Adjustments Of Switches, Socket Outlets And Fixed Outlets

a. General

Switches, sockets and fixed outlets shall be:

a) Flush type

b) Standard manufactured type, commonly available with clip-on metal or plastic coloured over plates

c) Standard manufactured type, commonly available plastic or polycarbonate color faceplates.

b. Surface Type

Surface type shall have:

a) Enclosures of the impact resistant, corrosion resistant, surface mounted type, as per pathways and spaces

b) Spare entries permanently plugged

c) An earth connection if metal clad.

c. Light Switches

Light switches shall be rated at 10A minimum unless specified otherwise.

Adjacent light switches on different phases shall be housed in separate or approved partitioned enclosures.

Lighting switches shall be mounted at 1m above the floor level, and within 200mm of the doorframe on the handle side unless indicated otherwise.

d. Socket Outlets

Socket outlets shall be:

a) Flat three-pin socket type incorporating a suitably rated switch for single- phase applications

b) Round five-pin socket type incorporating a suitably rated switch for three phase applications.

Note the requirements of NZS 4121 which requires outlets to be mounted 500mm above the floor for disability access. Switched socket outlets shall be located in relation to the equipment or appliance such that the isolation point is readily accessible. All newly installed RUPOs installed in schools shall be labeled to indicate their purpose and that RCD protection is provided, for example 'ICT USE ONLY – RCD PROTECTION' for ICT related RUPOs. All socket outlets (RUPOs and GPOs) shall be labeled with switchboard and circuit identification. Front cover plates shall be labeled with computer generated vinyl labels, this label shall also be replicated on the base plate using permanent marker.

e. Industrial Outlets

Single and poly-phase industrial socket outlets shall be:

- a) To AS/NZS 3123, or IEC 60309
- b) Supplied with matching plug
- c) Mounted 1000mm above floor level, unless indicated otherwise.

- **What must you do before making adjustments or doing repairs of electrical equipment?**

Disconnect the power supply before making adjustments or changing accessories. Remove any wrenches and adjusting tools before turning on a tool. Inspect the cord for fraying or damage before each use. Tag defective tools clearly with an "Out of service" tag and replace immediately with a tool in good running order

- **What is the first thing to consider in an electrical installation Why?**

Every electrical installation is verified initially, before being put into service, as well as periodically, during its utilization. The main reason for verification is to **check whether protection against electric shock is on the satisfying level**

What are the 3 types of wiring?

Types of wire used are :

- ❖ live wire (Red color)
- ❖ neutral wire(Black color)
- ❖ earth wire (Green color)



Figure 2.18 wiring

✓ **Steps for Wiring Your House**

Disconnect power. Cutting off power is the first thing to do before attempting to do any electric wiring in your home.

1. Mount electrical board.
2. Set up connection.
3. Add circuit breaker.
4. Optimize circuit breaker.
5. Mount electrical box.
6. Size your cables.

2.4 Reporting fault

Report on large industries the Forman or supervisor is often required to keep a report of the relevant events which happen on the plants for example how many people from your company are working on plants each day what goods were delivered whether there were any breakages or accidents and records of plant meetings attended. Some organizations have two separate documents, a plants diary to record daily events and a weekly report which is summary of the Weekes events extracted formed the site diary. The site diary remains on site and the weekly report is sent to head office to keep managers informed of the works progress.

A fault is any abnormal condition in a power system. The steady state operating mode of a power system is balanced 3-phase a.c .However, due to sudden external or internal changes in the system, this condition is disrupted.

When the insulation of the system fails at one or more points or a conducting object comes into contact with a live point, a short circuit or a fault occurs.

Page 80 of 102	Ministry of Labor and Skills Author/Copyright	Apply Basic Electrical Practices	Version -1 August 2022
----------------	--	----------------------------------	---------------------------

2.4.1 Causes of power system faults

The causes of faults are numerous

- Lightning
- Heavy winds
- Trees falling across lines
- Vehicles colliding with towers or poles
- Birds shorting lines
- Aircraft colliding with lines
- Vandalism
- Small animals entering switchgear
- Line breaks due to excessive loading

2.4.2 Common power system faults

Power system faults may be categorized as one of four types; in order of frequency of Occurrence, they are:

- Single line to ground fault
- Line to line fault
- Double line to ground fault
- Balanced three phase fault

2.4.3 Notify or report work completion

Inform or report to supervisor after completion of Install and terminate wiring system work. Inform or report to supervisor the matter to his/her supervisor or through his/her Union Representative or such other person as may be subsequently defined.

2.4.4 Respond unplanned events or condition

Respond unplanned events or condition means respond the unnecessary action or events in plan to the technician generally respond unplanned events or conditions to in accordance with established procedures

2.4.5 Obtain approval from appropriate personnel before any implement

Obtain approval from appropriate personnel before any contingency implement means Obtain Approval in accordance with established procedures from appropriate personnel before any implement contingencies in Perform installation and termination of wiring system.

Self check- 2

Test-I multiple Choose

1.The Electricity at Work Regulations tell us that before work commences on electrical equipment it must be disconnected from the source of supply and that disconnection must be secure. To comply with this Regulation we must:

- a) switch off the circuit at the local functional switch
- b) switch off the current at the local isolator switch
- c) follow a suitable electrical isolation procedure
- d) follow the test procedures given in Part 7 of the IEE Regulations (BS 7671)

2. To verify or prove a successful electrical isolation you would use a:

- a) voltage indicator
- b) voltage proving unit
- c) set of GS 38 test leads
- d) small padlock

3. To secure an electrical isolation you would use a:

- a) voltage indicator
- b) voltage proving unit
- c) set of GS 38 test leads
- d) small padlock

4. Where a test instrument or voltage indicator is used to prove a supply dead, the same device must be tested to show that it still works using a:

- a) voltage indicator
- b) voltage proving unit
- c) set of GS 38 test leads
- d) small padlock

Page 82 of 102	Ministry of Labor and Skills Author/Copyright	Apply Basic Electrical Practices	Version -1 August 2022
----------------	--	----------------------------------	---------------------------

5. To give adequate protection to the person carrying out a safe isolation procedure, the test instrument must incorporate a:

- | | |
|-------------------------|----------------------------|
| a) voltage indicator | c) set of GS 38 test leads |
| b) voltage proving unit | d) small padlock |

Test-II Matching question

- | | |
|----------------------------|----------------------------|
| 1. Live wire | a. rated at 10A minimum |
| 2. Earth wire | b. Green color |
| 3. Neutral wire | c. Red color |
| 4. One Steps for wiring | d. Disconnect power |
| 5. Light Switches shall be | e. Black color |
| 6. RCDs | f. residual current device |

Operation 2 Identify the means of electrical isolation

- **Operation title:** Observe electrical isolation
- **Purpose:** To Observe the means of electrical isolation
- **Instruction:** To identify the means of electrical isolation, **visit your work shop or your college** compound with your teacher or Trainer where the electrical supply distribution boards, sub distribution boards and final circuits. You are provided 4hour

- **Tools and requirement:**

- 1.Voltage indicator
- 2.Screw Drivers
- 3.Voltmeter
- 4.Fish tape
- 5.Wire striper
- 6.Mega-ohmmeters

- **Steps in doing the task**

Step 1: Check with the duty holder/authorized person that it is acceptable to isolate the circuit/equipment.

Step 2: Ensure that there is a ‘Permit to Work’ in place.

Step 3: Identify the type of supply system

Step 4: Locate and identify the circuit/equipment to be isolated including any alternative sources

Step 5: Select an approved voltage indicator device

Step 6: Verify the circuit/equipment is functional.

Step 7: Identify suitable means of isolation.

Step 8: Isolate circuit / equipment by:

Step 9: Fit appropriate lock off device and locks.

Step 10: Verify the circuit/equipment is isolated. Use the approved voltage indicator device to verify circuit is dead.

Step 11: Re-check the approved voltage indicator device is still functional

Step 12: Circuit/equipment should be safe to carry out the work.

- **Quality Criteria:** should fulfilled the legal requirement
- **Precautions:** Before you test the light, remove any hazards

Lap Test 2

Task-1: Observe and identify means of electrical isolation on the Energy meter supply side

Task-2: Observe and identify means of electrical isolation Distribution board

Task-3: Observe and identify means of electrical isolation in sub distribution boards

Operation sheet- 3 Maintenance of Electrode holder

- **Operation title:** Maintenance
- **Purpose:** Over time, the electrical resistance of the burn will be directly damaged, so it must be repaired
- **Instruction:** Use the given figure below (Figure), the tools and equipment also use and maintain properly according to the procedure



Figur 2.19 electrode holder

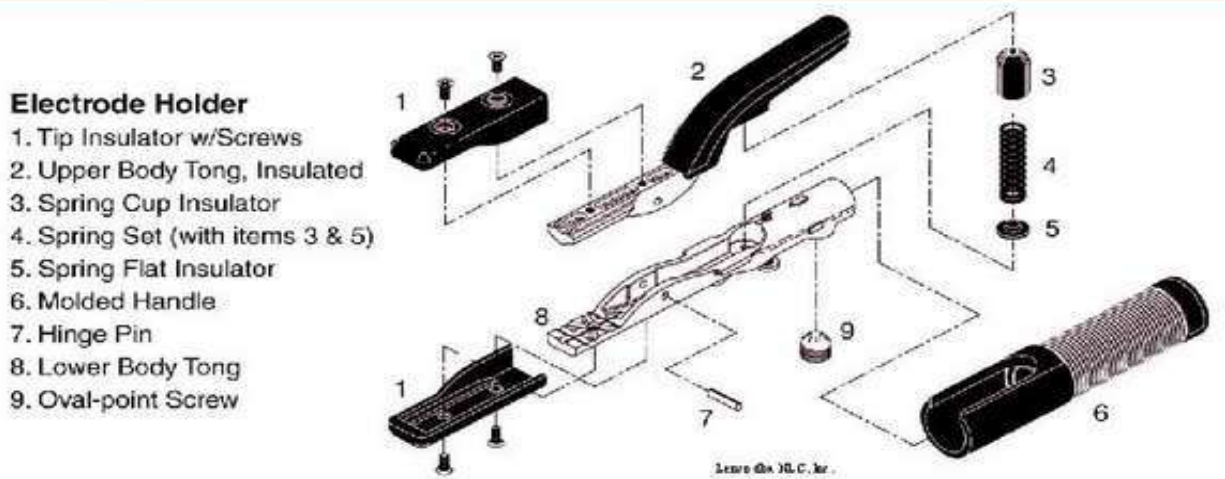

Figur 2.10 electrode holder parts

- **Tools and requirement:**

1. cable
2. Knife Stripping
3. allenkey
4. philipes screw drivers
5. vice
6. flat screw drivers

- **Steps in doing the task**

1. Power off
2. Put on the vise loos the damaged holder
3. Prepare 5mm Allen key and different screw driver
4. Loose the screws
5. Take out the tip
6. Strip the cable properly
7. Plating copper wire
8. Disassemble the new one and make sure the spring works
9. Inserting the cable into the holder
10. Fasten the screws using a screwdriver
11. Plug into the machine

- **Quality Criteria:** should fulfilled the maintenance requirement
- **Precautions:** Before you test the holder power of the machine

Lap Test-3

Task-1: dismantling properly

Task-2 Inserting the cable into the holder properly

Task-3 assembly the cable into the holder properly

Operation sheet- 4 Maintain your work shop **fluorescent tube light**

- **Operation title:** Maintenance & fuse changes
- **Purpose:** Making sure that a damaged lamp works by repairing it and doing maintenance practice
- **Instruction:** To identify the damaged lamp **visit your work shop or your college** compound with your teacher or Trainer where the electrical supply distribution boards, switches and breakers check and proper the damages present lamp. sub You are provided 4hour
- **Quality Criteria:** should fulfilled the maintenance requirement
- **Precautions:** Before you loss the **fluorescent tube** lamp power of the sorces.

- **Tools and requirement:**

1. wire
2. Knife Stripping
3. alenkey
4. philipes screw drivers
5. stareter fuse
6. flat screw drivers

- **Steps in doing the task**

1. Simply put, fluorescent starters are a timed switch.
2. switch opens and closes until the fluorescent tube 'strikes'
3. lights-up. If the fluorescent tube does not light,
4. repeats it's switch open/close cycle and the fluorescent tubes attempts to ignite again.

Below

Page 86 of 102	Ministry of Labor and Skills Author/Copyright	Apply Basic Electrical Practices	Version -1 August 2022
----------------	--	----------------------------------	---------------------------

Lap Test-4

Task-1: dismantling properly

Task-2 Inserting the cable into the holder properly

Task-3 assembly the cable into the holder properly

Unit Three: Notify the completion of quality work

This learning guide is developed to provide you the necessary information regarding the following content coverage and topics:

- Complete work responsible personnel
- final checks with supervisor
- restored work area
- storing plant, tools and equipment

This guide will also assist you to attain the learning outcomes stated in the cover page. Specifically, upon completion of this learning guide, you will be able to:

- Finalize work for responsible personnel
- Make final checks with supervisor
- Secure restored work area
- Maintain storing plant, tools and equipment

3.1 Complete Work Responsible Personnel

The Wiring Regulations (BS 7671) is the Electricians' Bible and provides the authoritative framework for anyone working in the electro-technical industry. To assist workers in the electro-technical industry with their understanding of the relevant regulations many guidance booklets have been published, particularly:

- ❖ The *On Site Guide* published by the IEE
- ❖ Guidance Note 1: Selection and erection of equipment
- ❖ Guidance Note 2: Isolation and Switching
- ❖ Guidance Note 3: Inspection and Testing
- ❖ Guidance Note 4: Protection against Fire
- ❖ Guidance Note 5: Protection against Electric Shock

Page 87 of 102	Ministry of Labor and Skills Author/Copyright	Apply Basic Electrical Practices	Version -1 August 2022
----------------	--	----------------------------------	---------------------------

- ❖ Guidance Note 6: Protection against Over current
- ❖ Guidance Note 7: Special Locations

All the above publications are published by the IEE and are available from IEE Publications
 Good communication is about transferring information from one person to another. How many hours or days did you spend on a particular job last week?

How does your boss know how many hours of work you put in on that job, so that a charge to the customer for your time can be made? How much material did you use on that job last week? How does your boss know how much material you used, so that a charge to the customer can be made for it?

Most electrical companies have standard forms which help them to keep track of time put in and materials used. When completing standard forms, follow the instructions given and make sure that your writing is legible – print if it makes your writing clearer. Finally, read through the form to make sure that you have completed all the relevant sections. Now, let us look at five standard forms used by most electro-technical companies.

- **Time Sheets**

A time sheet is a standard form completed by each employee to inform the employer of the actual time spent working on a particular contract or site. This helps the employer to bill the hours of work to an individual job. It is usually a weekly document and includes the number of hours worked, the name of the job and any travelling expenses claimed. Office personnel require time sheets such as that shown in Table 7 so that wages can be made up.

TIME SHEET				FLASH-BANG ELECTRICAL		
Employee's name (Print)						
Week ending						
Day	Job number and/or Address	Start time	Finish time	Total hours	Travel time	Expenses
Monday						
Tuesday						
Wednesday						
Thursday						
Friday						
Saturday						
Sunday						
Employee's signature				Date		

Table 7 Time Sheets

- **Job Sheets**

A job sheet or job card such as that shown in table 8 carries information about a job which needs to be done, usually a small job. It gives the name and address of the customer, contact telephone numbers, often a job reference number and a brief description of the work to be carried out. A typical job sheet work description might be:

- Job 1 – Upstairs lights not working
- Job 2 – Funny fishy smell from kettle socket in kitchen

The time spent on each job and the materials used are sometimes recorded on the job sheets, but alternatively, a day work sheet can be used. This will depend upon what is normal

practice for the particular electrical company. This information can then be used to ‘bill’ the customer for work carried out.

JOB SHEET	FLASH-BANG ELECTRICAL
Job Number	
Customer name	
Address of job	
.....	
Contact telephone no.	
Work to be carried out	
.....	
.....	
Any special instructions/conditions/materials used	

Table 8 Job Sheets

- **Day work Sheets**

Day work is one way of recording variations to a contract, that is, work done which is outside the scope of the original contract. If day work is to be carried out, the site supervisor must first obtain a signature from the client’s representative, for example, the Architect, to authorize the extra work. A careful record must then be kept on the day work sheets of all extra time and materials used so that the client can be billed for the extra work and materials. A typical day work sheet is shown in table 9

FLASH-BANG ELECTRICAL					DAYWORK SHEET	
Client name						
Job number/ref.						
Date	Labour	Start time	Finish time	Total hours	Office use	
.....	
.....	
Materials quantity		Description			Office use	
.....		
.....		
Site supervisor or F.B. Electrical Representative responsible for carrying out work						
Signature of person approving work and status e.g.						
Client <input type="checkbox"/>	Architect <input type="checkbox"/>	Q.S. <input type="checkbox"/>	Main contractor <input type="checkbox"/>	Clerk of works <input type="checkbox"/>		
Signature						

Table 9 Day work Sheet

- **Delivery Notes**

When materials are delivered to site, the person receiving the goods is required to sign the driver’s ‘Delivery Note’. This record is used to confirm that goods have been delivered by the supplier, who will then sent out an invoice requesting payment, usually at the end of the month.

The person receiving the goods must carefully check that all items stated on the Delivery Note have been delivered in good condition. Any missing or damaged items must be clearly indicated on the Delivery Note before signing because, by signing the Delivery Note the

person signing is saying ‘yes, these items were delivered to me as my company’s representative on that date and in good condition and I am now responsible for those goods’. Suppliers will replace materials damaged in transit, provided that they are notified within a set period, usually three days. The person receiving the good should try to quickly determine their condition has the packaging been damaged – does the container ‘sound’ like it might contain broken items? It is best to check at the time of delivery if possible or as soon as possible after delivery and within the notify able period. Electrical goods delivered to site should be handled carefully and stored securely until they are installed. Copies of Delivery Notes should be sent to Head Office so that payment can be made for the goods received.

3.2 Final Checks with Supervisor

On completion of a wiring installation, a number of tests on the installation have to be conducted to ascertain that the wiring circuits and connected appliances are safe for use. Prior to carrying out the tests, an inspection has to be done.

There are different types of testing methods in wiring installation. Two of these are:

- I. Continuity Test
- II. Polarity Test

3.2.1 Continuity Test

There are 3 main types of continuity tests for the final circuits:-

- a) Protection Conductor Continuity Test.
- b) Final Ring Circuit Conductor Continuity Test.
- c) Live and Neutral Conductor Continuity Test.

a) Protection Conductor Continuity Test

- To ascertain that all protection conductors are connected in the correct and effective manner.
- Test equipment – Multi-meter (Ohm range) or Ohm meter.
- Test Method:
 - ✓ Ensure that the main switch, RCD and MCB are open circuited (switched off) and all loads are disconnected;
 - ✓ Connected the test leads as in the Figure 3.2
 - ✓ The meter reading shall be less than 1 ohm.

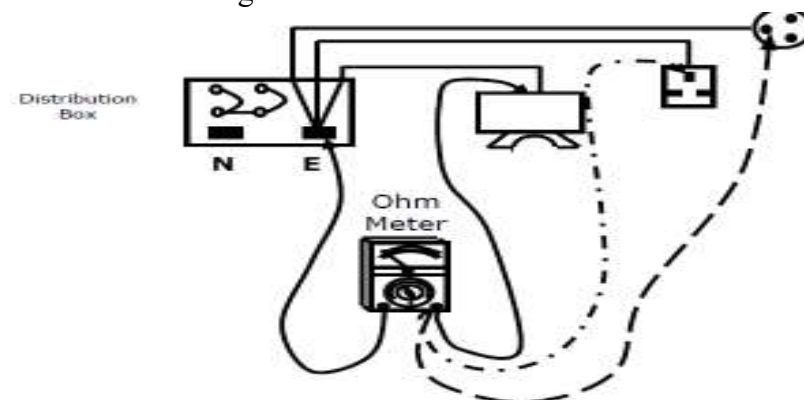

Figure 3.1 Protection Conductor Continuity Test

b) Final Ring Circuit Conductor Continuity Test

- To ensure that all conductors around the ring circuit have continuity;
- Test Equipment :- Multi-meter (Ohm range) or Ohm Meter
- Test Method:
 - ✓ Disconnect both the supply source live conductors from the MCB, the neutral conductor from the neutral terminals and the earth conductor from the earth terminal in the distribution fuse box;
 - ✓ Connect the test leads as in the Figure 1.72 (EE);
 - ✓ Repeat the procedure for (L-L) and (N-N);
 - ✓ The meter reading value shall be less than 1 ohm.

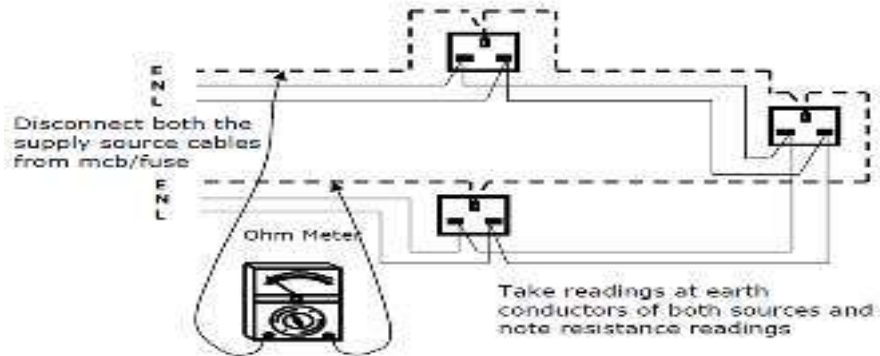

Figure 3.2 Final Ring Circuit Conductor Continuity Test

c) Live and Neutral Conductor Continuity Test

- To ensure that each conductor in the circuit has continuity;
- Test Equipment – Multi-meter (Ohm range) or Ohm Meter
- Test Method:
 - ✓ Switch off the Main switch, RCD and MCB;
 - ✓ Disconnect all loads;
 - ✓ Switch on all switches in the circuit;
 - ✓ Disconnect the fuses/final circuit breakers and close the circuit;
 - ✓ Carry out the test as shown in Figure 1.73;
 - ✓ The meter reading value shall be less than 1 ohm.

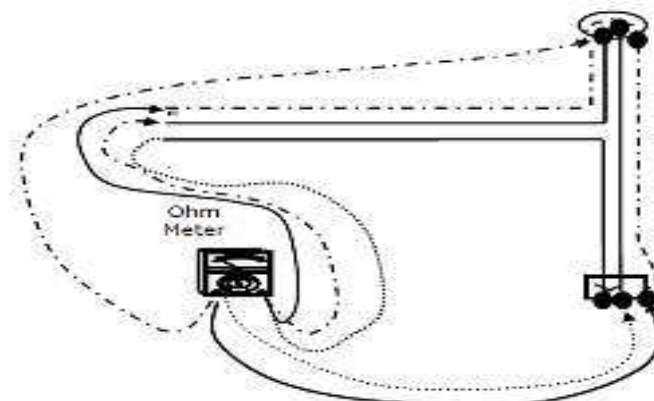

Figure 3.3 Live and Neutral Conductor Continuity Test

3.2.2 Polarity Test

- Ensure that each fuse or single pole control and protection device is connected only in the phase conductor.

- Intermediate contact of Edison screw lamp holder is connected to the phase conductor.
- Ensure that phase, neutral and earth conductors at socket outlets are connected at the correct terminals.
- Test Equipment: - Multi-meter (Ohm range) or Ohm meter.
- Test Method:
 - ✓ Switch off Main switch;
 - ✓ Disconnect all loads
 - ✓ Switch on all circuit control switches;
 - ✓ Carry out test as in Figure 1.74;
 - ✓ Test switches and single phase control devices at the phase conductors.
 - ✓ Test socket outlet connection sources.
 - ✓ Test Edison screw lamp holder connections.
 - ✓ Meter reading value shall be less than 1 ohm.

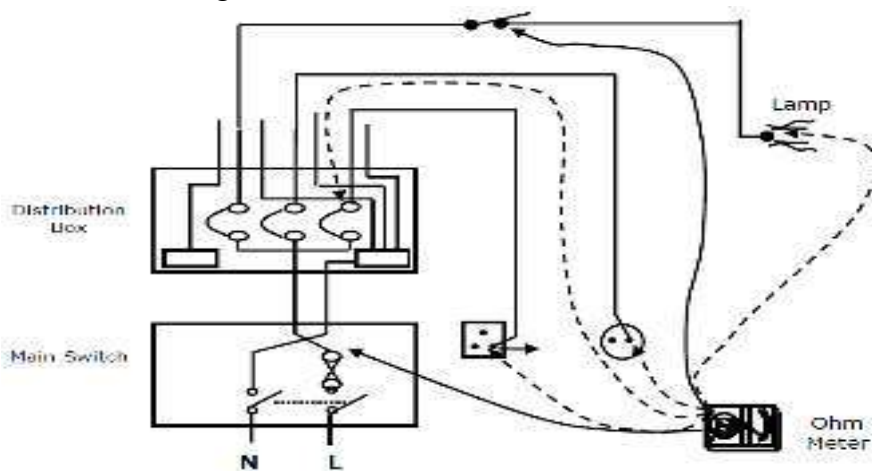

Figure 3.4 Polarity Test



Figure 3.5 Testing

Inspection

Check the following items to ensure:

Page 92 of 102	Ministry of Labor and Skills Author/Copyright	Apply Basic Electrical Practices	Version -1 August 2022
----------------	--	----------------------------------	---------------------------

- A. All mechanical connections are tight, as factory connections may loosen during shipment and storage.
- B. All accessible electrical connections are tightened to the torque specifications on the panel labeling.
- C. All screws connecting and tight switches, breakers, socket outlets, lamps, etc are properly installed and tightened.
- D. Connections between branch circuits and breakers are properly secured.
- E. All ground connections are properly made (Note: ground wire must be installed after the panel box is mounted on the wall).
- F. All foreign materials have been removed from the panel and enclosure before installing the dead front and trim.
- G. Before energizing – Dead front is properly aligned and securely installed.
- H. Before energizing – Trim is properly mounted and securely installed.

Before the electrical wiring is energized, it must be thoroughly inspected and tested. Any deviation must be corrected prior to energizing.

Introduction Periodic inspection and testing of internal wiring installations is necessary. Internal wiring should be checked and corrected every work for safe operations. While carrying out inspection and testing of internal wiring installations, following point's correction action must be carried out.

Correction action for Electrical wiring and enclosures tested and inspected

- ❖ Tester or inspector Name: ----- Date: -----

- ❖ Types of tested and inspected circuit: _____
Location/Client: _____
- ❖ Installation type (New/addition/alteration of exist installation): _____

No	Inspecting and Testing activities	Correction Action for Inspected and Tested activities
A	Inspecting	After Inspection
1	All mechanical connections are tight, as factory connections may loosen during shipment and storage.	Check and retighten all mechanical connections
2	All accessible electrical connections are tightened to the torque specifications on the panel labeling.	Check and retighten all All accessible electrical connections
3	All screws connecting and tight switches, breakers, socket outlets, lamps, etc are properly installed and tightened	Check, reinstall and retighten All screws connecting and tight switches, breakers, socket outlets, lamps, etc
4	Connections between branch circuits and breakers are properly secured.	Check and reconnect the connections between branch circuits and breakers
5	All ground connections are properly made (Note:	Check and reconnect the all ground connections

	ground wire must be installed after the panel box is mounted on the wall).	
6	All foreign materials have been removed from the panel and enclosure before installing the dead front and trim.	Check and remove foreign materials from the panel and enclosure
7	Dead front is properly aligned and securely installed.	Check, re-align and re-secure dead fonts
8	Trim is properly mounted and securely installed.	Check, re-mount and re-secure installation
B	Continuity Test	After Continuity Test
1	Conductors are connected in the correct and effective manner.	Check and reconnect the conductors
2	all conductors around the ring circuit have continuity	check and reconnect the ring circuits
3	Live and Neutral Conductor Continuity Test	check and reconnect the Live and Neutral Conductor
C	Polarity test	After Polarity test
1	Each fuse or single pole control and protection device is connected only in the phase conductor.	check and reconnect fuse or single pole control and protection device in the phase wire
2	Intermediate contact of Edison screw lamp holder is connected to the phase conductor	check and reconnect Edison screw lamp holder Intermediate contact to phase conductor
3	phase, neutral and earth conductors at socket outlets are connected at the correct terminals	check and reconnect phase, neutral and earth conductors at socket outlets correct terminals
D	Over all functionality test	After Over all functionality test
1	Light circuits are functional	Check and rewire the light circuit
2	Control and protective devices are functional	Check, reconnect, rewire or replace Control and protective devices
3	General purpose socket outlets are functional	Check, reconnect, rewire or replace General purpose socket outlets
4	Metallic body of electrical devices are grounded	Check, reconnect, rewire and ground the metallic body of electrical devices

Table 10 for tested and inspected

3.3 Restored Work Area

Definition: - clean work area and dispose of ,reuse or recycle materials according to legislation/regulation/code means clean work area before starting any work and after completion of work and dispose of ,reuse or recycle materials is classify types of materials with their function and identify by dispose, reuse or recycle after use the original materials.

3.3.1 Clean, Check, Maintain And Store Plant, Tools And Equipment

Definition: - clean, check, maintain and store Plant, tools and equipment means clean, check, maintain tools and equipment before Install and terminate wiring system and clean work area and store after completion of Install and terminate wiring system

- Fire extinguishers are for dealing with small fires and different types of fire must be attacked with a different type of extinguisher. Figure 11 shows the correct type of

extinguisher to be used on the various categories of fire. The color coding shown is in accordance with BS EN3:1996.

Type of fire extinguisher \ Type of fire	(i) Water Signal red flash on red	(ii) Foam Pale cream flash on red	(iii) Carbon dioxide gas Black flash on red	(iv) Dry powder French blue flash on red	(v) Vapourizing foam Emerald green flash on red
CLASS A. Paper, Wood and Fabric	✓ Yes	✓ Yes	✗ No	✓ Yes	✓ Yes
CLASS B. Flammable Liquids	✗ No	✓ Yes	✓ Yes	✓ Yes	✓ Yes
CLASS C. Flammable Gases	✗ No	✗ No	✓ Yes	✓ Yes	✓ Yes
Electrical fires	✗ No	✗ No	✓ Yes	✓ Yes	✓ Yes
Motor vehicle protection	✗ No	✓ Yes	✗ No	✓ Yes	✓ Yes

Figure 3.6 Fire Extinguishers and their Applications

3.3.2 Electrical Emergencies

- Injury could be minimized and many lives saved if proper rescue techniques and treatment are used.
- Electrical accidents may occur at almost any time or place. Timely response and treatment of victims is a major concern. You must use your best judgment in an electrical emergency.
- Do you know the proper actions to take? Do you know what dangers could be encountered?
- When an electrical accident occurs, due to the effect of muscle clamping, a victim is often incapable of moving or releasing the electrical conductor.
- Attempts to rescue an accident victim may pose as great a hazard for the rescuer as it does for the victim. Caution should be a primary consideration during any electrical accident or emergency. There should always be an emergency response plan for scheduled electrical maintenance or work.

3.3.3 Electrical Rescue Techniques

- **Approaching the accident:**
 - ✓ Never rush into an accident situation.
 - ✓ Call to emergence workers as soon as possible.
 - ✓ Get the aid of trained electrical personnel if possible.
 - ✓ Approach the accident scene cautiously.
- **Examining the scene:**
 - ✓ Visually examine victims to determine if they are in contact with energized conductors.
 - ✓ Metal surfaces, objects near the victim or the earth itself may be energized.
 - ✓ You may become a victim if you touch an energized victim or conductive surface.

- ✓ Do not touch the victim or conductive surfaces while they are energized.
- ✓ De-energize electrical circuits if at all possible.

3.4 Maintaining and Storing Tools & Equipment

An important aspect of any business is the maintenance and storage of tools and equipment. The investment in tools and equipment is a significant part of the overhead expenses in any operation. Proper selection and maintenance of equipment are important factors in managing business. Selecting the proper tool for the job and using the tool properly will increase efficiency and reduce maintenance problems. Purchase tools, which are well-made and suited to the intended use. Commercial usage may entail more heavy duty demands on equipment.

Hand tools:

1. Clean dirt and debris from tools after each use.
2. Oil metal parts to prevent rust.
3. Lightly sand rough wooden handles and apply linseed oil.
4. Repair loose handles.
5. Sharpen blades of cutting tools.
6. Store tools in a clean dry storage area.
7. Protect surfaces of cutting tools in storage.

Power tools:

1. Read and follow the maintenance schedule in the owner's manual for each piece of power equipment.
2. Change the oil.
3. Clean the air filter.
4. Lubricate moving parts.
5. Sharpen dull blades or replace worn blades according to the owner's manual.
6. Replace spark plugs.
7. Drain oil and gasoline before long-term storage.
8. Check electric cords and connections on electric-powered tools.
9. Store tools in a clean dry storage area.

Equipment:

1. Store equipment in a clean dry storage area.
2. Rinse and clean spray equipment after each use.
3. Clean spreaders and check wheel-driven gears.
4. Clean carts and wheelbarrows after use

Sample Proper Arrangement and storage of tools and equipment



Figure 3.7 Classification of non-functional and functional tools

Tools are very useful to us in our homes especially to our job. But tools that are no longer Functional may cause harm.

- A. Make an inventory of functional and non-functional tools in your shop.
- B. Classify your tools according to is function.

3.4.2 Method of identifying non-functional tools and equipment

1. Visual inspection. It refers to the visual observation of an expert on the appearance of the tools and equipment.
2. Functionality. Vibration or extra noise from the operation means problems on parts and accessories started to develop.
3. Performance. When there is something wrong with the performance of either hand tools or equipment they need an immediate repair or maintenance.
4. Power supply (for electrically operated only). Failure to meet the required power supply, malfunction will occurs in the part of hand tools or equipment.
5. Person’s involved. It refers to the technical person who has the knowledge and skills about the technology.

Non-functional tools and equipment are those that are not able to perform its regular function because of impaired and damage part. Examples of these are the following:

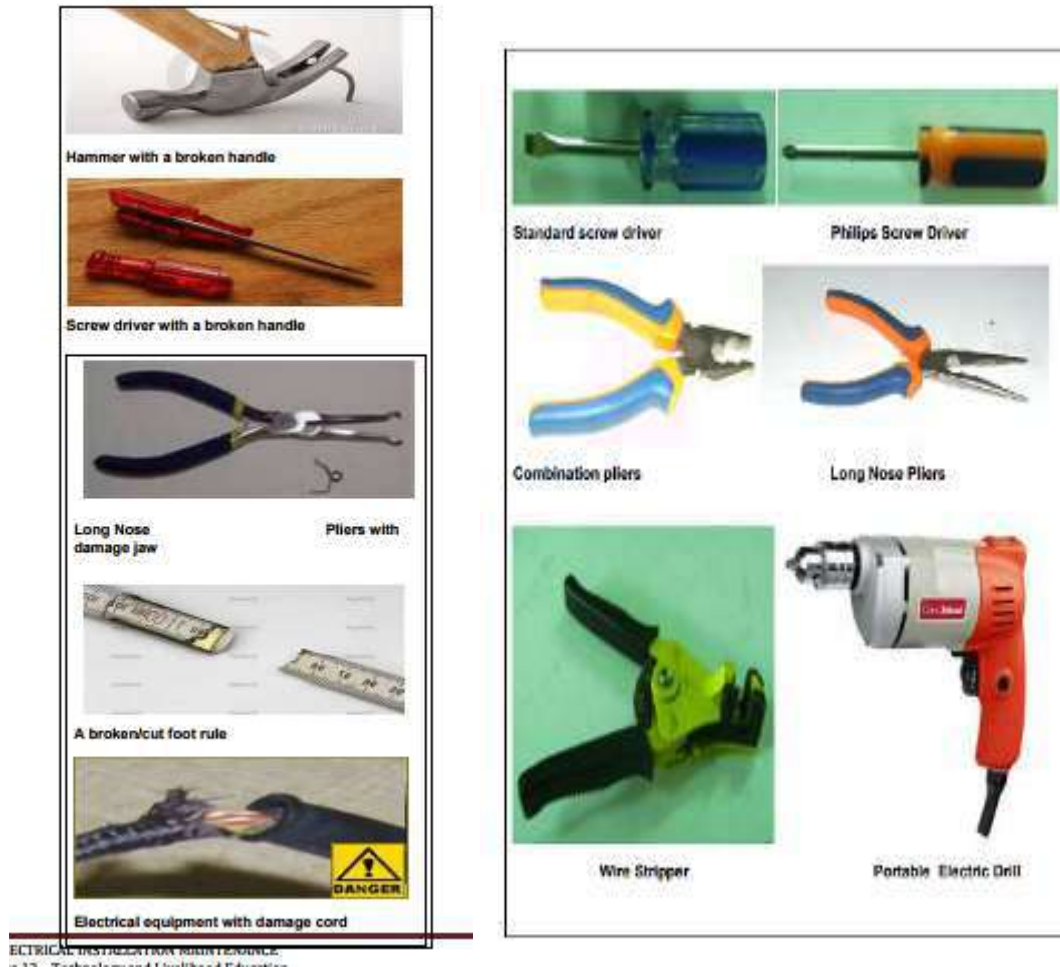

Figure 3.8 Tools and equipment



Figure 3.9 List of electrical and electronic measuring equipment

Name	Purpose
Ammeter (Ampermeter)	Measures current
Capacitance meter	Measures the capacitance component
Current clamp	Measures current without physical connection
Curve tracer	Applies swept signals to a device and allows display of the response

Self-check -3

Test-I multiple Choose

- 1) A Time Sheet shows:
 - a) a record of goods delivered by a supplier
 - b) a record of work done which is outside the original contract
 - c) information about work to be done, usually a small job
 - d) the actual time spent working on a particular job or site
- 2) A Job Sheet or Job Card shows:
 - a) a record of goods delivered by a supplier
 - b) a record of work done which is outside the original contract
 - c) information about work to be done, usually a small job
 - d) the actual time spent working on a particular job or site
- 3) A Day Work Sheet shows:
 - a) a record of goods delivered by a supplier
 - b) a record of work done which is outside the original contract
 - c) information about work to be done, usually a small job
 - d) the actual time spent working on a particular job or site
- 4) A Delivery Note shows:
 - a) a record of goods delivered by a supplier
 - b) a record of work done which is outside the original contract
 - c) information about work to be done, usually a small job
 - d) the actual time spent working on a particular job or site

Test-II Matching

- | | |
|-----------------------|---------------------------------|
| 1. Ammeter | a. Measures the capacitance |
| 2. Capacitance meter | b. Measures current |
| 3. Fire extinguishers | c. protect electrical emergency |
| 4. Test Equipment | d. multi-meter |

Test-III : Short answer

1. _____ is an instrument for measuring the electric power (or the supply rate of electrical energy) in watts of any given circuit.
2. _____ is a measuring instrument used to measure the electric current in a circuit.
3. _____ are hand tools, designed primarily for gripping objects by using leverage.
4. _____ are forms of protective eyewear that usually enclose or protect the eye area in order to prevent particulates, water or chemicals from striking the eyes.
5. _____ are cutting tools used to create holes.
6. _____ is a tool with a rotating drill bit used for drilling holes in various materials.
7. Drills are commonly used in _____, _____ & _____
8. _____ is an instrument used in geometry, technical drawing and engineering/building to measure distances and/or to rule straight lines.
9. _____ is a saw for cutting metal or bones.
10. A _____ is a hand tool for drilling small holes, mainly in wood, without splitting.
11. The _____ is a device specifically designed to insert and tighten, or to loosen and remove, screws.
12. _____ cuts and removes insulation on electrical wire while leaving the wire intact
13. A _____ is an instrument used for measuring the electrical potential difference between two points in an electric circuit.

